

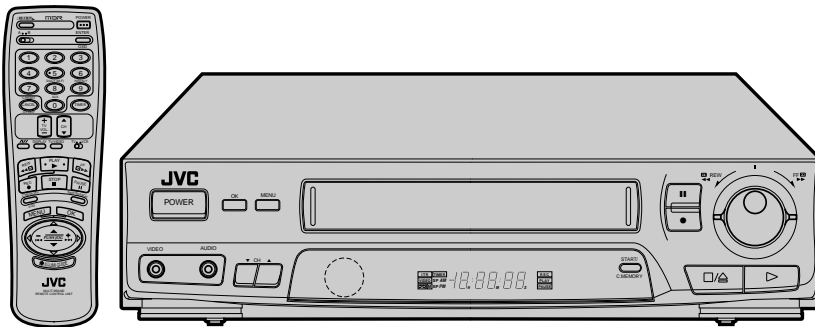

JVC

VIDEO CASSETTE RECORDER

HR-J430KR



G-CODE
VHS



INSTRUCTIONS

For Customer Use:

Enter below the Serial No. which is located on the rear of cabinet. Retain this information for future reference.

Model No. **HR-J430KR**

Serial No. _____



PU30425-1930



Dear Customer,

Thank you for purchasing the JVC VHS video cassette recorder. Before use, please read the safety information and precautions contained in the following pages to ensure safe use of your new VCR.

CAUTIONS

	CAUTION RISK OF ELECTRIC SHOCK DO NOT OPEN	
<p>CAUTION: TO REDUCE THE RISK OF ELECTRIC SHOCK, DO NOT REMOVE COVER (OR BACK). NO USER-SERVICEABLE PARTS INSIDE. REFER SERVICING TO QUALIFIED SERVICE PERSONNEL.</p>		



The lightning flash with arrowhead symbol, within an equilateral triangle, is intended to alert the user to the presence of uninsulated "dangerous voltage" within the product's enclosure that may be of sufficient magnitude to constitute a risk of electric shock to persons.



The exclamation point within an equilateral triangle is intended to alert the user to the presence of important operating and maintenance (servicing) instructions in the literature accompanying the appliance.

WARNING: TO PREVENT FIRE OR SHOCK HAZARD, DO NOT EXPOSE THIS UNIT TO RAIN OR MOISTURE.

CAUTION:

This video cassette recorder should be used with AC 110V-220V~, 60Hz only.
To prevent electric shocks and fire hazards, DO NOT use any other power source.

CAUTION:

TO PREVENT ELECTRIC SHOCK, MATCH WIDE BLADE OF PLUG TO WIDE SLOT, FULLY INSERT.

ATTENTION:

POUR ÉVITER LES CHOCS ÉLECTRIQUES, INTRODUIRE LA LAME LA PLUS LARGE DE LA FICHE DANS LA BORNE CORRESPONDANTE DE LA PRISE ET POUSSER JUSQU'AU FOND.

Note to CATV system installer:

This reminder is provided to call the CATV system installer's attention to Article 820-40 of the NEC that provides guidelines for proper grounding and, in particular, specifies that the cable ground shall be connected to the grounding system of the building, as close to the point of cable entry as practical.

CAUTION:

Changes or modifications not approved by JVC could void user's authority to operate the equipment.

Failure to heed the following precautions may result in damage to the VCR, remote control or video cassette.

- DO NOT place the VCR . . .**
 - ... in an environment prone to extreme temperatures or humidity.
 - ... in direct sunlight.
 - ... in a dusty environment.
 - ... in an environment where strong magnetic fields are generated.
 - ... on a surface that is unstable or subject to vibration.
- DO NOT block the VCR's ventilation openings.**
- DO NOT place heavy objects on the VCR or remote control.**
- DO NOT place anything which might spill on top of the VCR or remote control.**
- AVOID violent shocks to the VCR during transport.**

****MOISTURE CONDENSATION**

Moisture in the air will condense on the VCR when you move it from a cold place to a warm place, or under extremely humid conditions—just as water droplets form on the surface of a glass filled with cold liquid. Moisture condensation on the head drum will cause damage to the tape. In conditions where condensation may occur, keep the VCR's power turned on for a few hours to let the moisture dry.

****ABOUT HEAD CLEANING**

Accumulation of dirt and other particles on the video heads may cause the playback picture to become blurred or interrupted. Be sure to contact your nearest JVC dealer if such troubles occur.

HOW TO USE THIS INSTRUCTION MANUAL

- All major sections and subsections are listed in the Table Of Contents on page 3. Use this when searching for information on a specific procedure or feature.
- The Index on pages 42 – 43 lists frequently-used terms, and the number of the first page on which they are used or explained in the manual. This section also illustrates the controls and connections on the front and rear panel, the front display panel and the remote control.
- The  mark signals a reference to another page for instructions or related information.
- Operation buttons necessary for the various procedures are clearly indicated through the use of illustrations at the beginning of each major section.

BEFORE YOU INSTALL YOUR NEW VCR . . .

. . . please read thoroughly the cautions on this page.

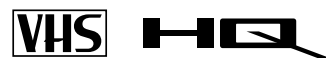

- Cassettes marked "VHS" (or "S-VHS") can be used with this video cassette recorder. However, only "VHS" recordings can be played back in this model.
- HQ VHS is compatible with existing VHS equipment.
- G-Code is a trademark applied for by Gemstar Development Corporation.
G-Code system is manufactured under licence from Gemstar Development Corporation.

I **NSTALLING YOUR NEW VCR** **4**

Basic Connections4

I **NITIAL SETTINGS** **5**

Clock5

Tuner6

Set Receivable Channels 6

Add Or Delete A Channel 8

G-Code Setup9

S **IMPLE PLAYBACK AND RECORDING** **12**

Simple Playback 12

Simple Recording 13

P **LAYBACK AND RECORDING FEATURES** **14**

Playback 14

Still Picture/Frame-By-Frame Playback 14

Slow Motion/Reverse Slow Motion 14

Variable-Speed Search/Reverse Play 15

High-Speed Search 15

Manual Tracking 16

Superimpose 17

Skip Search 18

Repeat Playback 18

Index Search 18

Instant ReView 19

Counter Reset 19

Counter Memory 19

Tape Position Indicator 20

Next-Function Memory 20

B.E.S.T. Picture System 21

Preparation 21

Recording 22

Playback 23

Recording 24

Record One Program While

Watching Another 24

Display Elapsed Recording Time 24

T **IMER RECORDING** **25**

Instant Timer Recording (ITR) 25

G-Code Timer Programming 26

On-Screen Timer Programming 28

Check And Cancel Programs 30

Auto SP/EP Timer 31

Auto Timer 32

S **PECIAL FEATURES** **33**

TV Multi-Brand Remote Control 33

E **DITING** **34**

Edit From A Camcorder 34

Edit To Or From Another VCR 35

Control Two JVC VCRs 35

Random Assemble Editing 36

T **ROUBLESHOOTING** **38**

Power 38

Tape Transport 38

Playback 38

Recording 38

Timer Recording 39

Other Problems 39

Q **UESTIONS AND ANSWERS** **40**

Playback 40

Recording 40

Timer Recording 40

S **PECIFICATIONS** **41**

I **NDEX** **42**

Front View 42

Rear View 42

Front Display Panel 43

Remote Control 43

Basic Connections

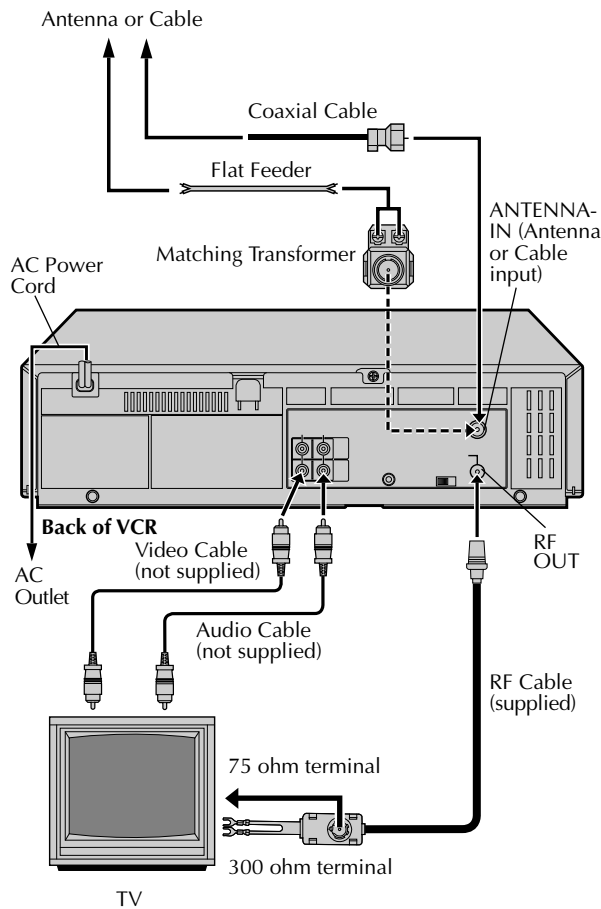

Back of VCR

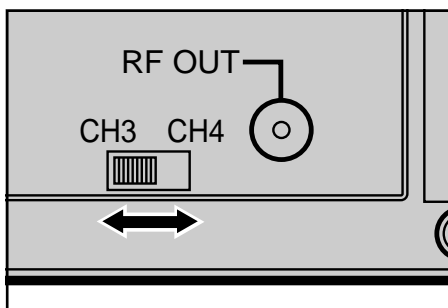

1

CHECK CONTENTS

Make sure the package contains all of the accessories listed in "SPECIFICATIONS" (☞ pg. 41).

2

SITUATE VCR

Place the VCR on a stable, horizontal surface.

3

CONNECT VCR TO TV

The connection method you use depends on the type of TV you have.

RF Connection

- To Connect To A TV With NO AV Input Terminals . . .
 - a- Disconnect the TV antenna from the TV.
 - b- Connect the TV antenna cable to the ANT IN jack on the rear of the VCR.
 - c- Connect the supplied RF cable between the RF OUT jack on the rear of the VCR and the TV's antenna terminal.

AV Connection

- To Connect To A TV With AV Input Terminals . . .
 - a- Connect the antenna, VCR and TV as shown in the illustration.
 - b- Connect an Audio/Video Cable between the AUDIO OUT and VIDEO OUT jacks on the rear of the VCR and the AV IN jacks on the TV.

4

CONNECT VCR TO POWER SOURCE

Connect the power plug to an AC outlet.

5

FINAL PREPARATION FOR USE

Select the VCR channel (3 or 4) by setting the switch on the rear of the VCR as shown in the illustration.

Turn on the power to the TV. You are now able to perform simple playback (☞ pg. 12) and recording (☞ pg. 13).

NOTES:

- The VCR channel is the channel on the TV which will display the audio and video signals from the VCR. The VCR's CH3-CH4 switch sets the VCR channel to CH3 or CH4.
- The CH3-CH4 switch is preset to the CH3 position. Set to CH4 if CH3 is used for broadcasting in your area.
- If your TV has no AV input terminals, set the channel on the TV to correspond to the CH3-CH4 switch on the back of the VCR.
- Even if your TV has AV input terminals, you must connect it to the VCR using an RF cable in order to record one show while watching another (☞ pg. 24).
- For full identification of the VCR's rear panel, refer to the Index (REAR VIEW ☞ pg. 42).

Clock

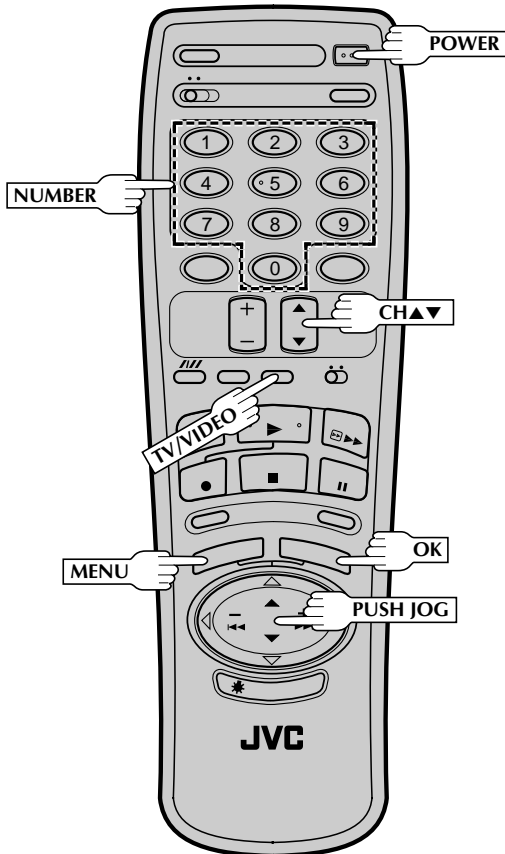
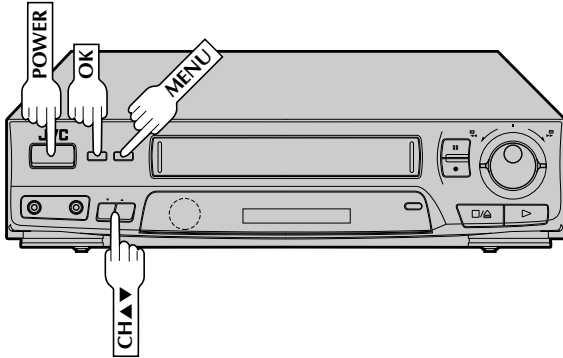

1 TURN ON THE VCR

Press **POWER**. If watching channel 3 or 4, press **TV/VIDEO** to select the VIDEO mode. VIDEO is displayed on the front display panel.

2 ACCESS ON-SCREEN MENU

Press **MENU** to bring up the Main Menu screen.

3 ACCESS INITIAL SET SCREEN

At the Main Menu screen, place the arrow next to "INITIAL SET" by pressing **CH▲▼** or **PUSH JOG▲▼**, then press **OK**.

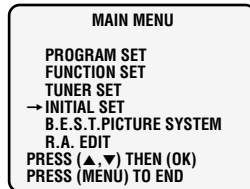

4 ACCESS CLOCK SET SCREEN

Place the arrow at the Initial Set screen next to "CLOCK SET" by pressing **CH▲▼** or **PUSH JOG▲▼**, then press **OK**.



5 SET DATE AND TIME

Press the appropriate **NUMBER** keys to set the date and time (if only 1 digit, press "0" first). Press **CH▲▼** or **PUSH JOG▲▼** to set AM/PM, then press **OK**. The next setting that can be set begins flashing. When you're finished with this set-up procedure, press **MENU** to start the clock.

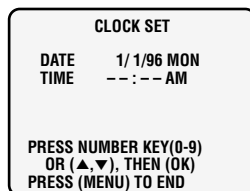

NOTE:

CH▲▼ or **PUSH JOG▲▼** can be used to perform all operations. (In this case, press **OK** after each setting.)

6 MAKE CORRECTIONS

To change any of the settings, press **OK** or **PUSH JOG** **◀▶▶▶▶** until the item you want to change blinks, then set as in step 5.

Tuner

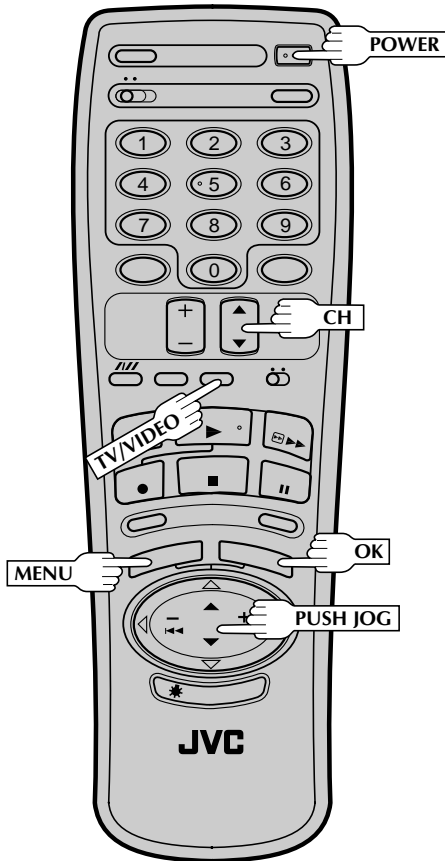
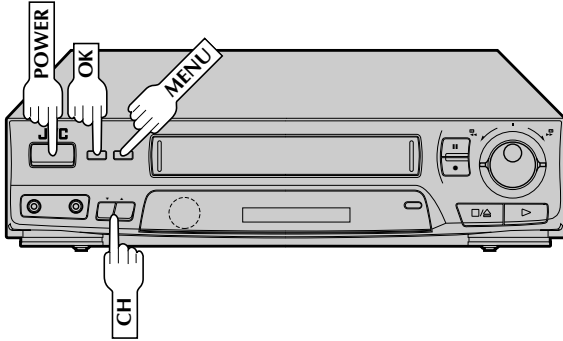

Set Receivable Channels

1 TURN ON THE VCR

Press **POWER**. If watching on channel 3 or 4, press **TV/VIDEO** to select the VIDEO mode. VIDEO is displayed on the front display panel.

2 ACCESS MAIN MENU SCREEN

Press **MENU** as many times as necessary .

3 ACCESS TUNER SET SCREEN

Place the arrow next to "TUNER SET" by pressing **CH▲▼** or **PUSH JOG▲▼**, then press **OK**.

4 ACCESS BAND SCREEN

Place the arrow next to "BAND" by pressing **CH▲▼** or **PUSH JOG▲▼**, then press **OK**.

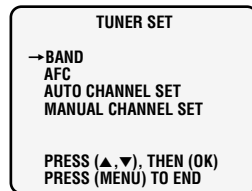

5 SET FREQUENCY BAND

If you receive your TV channels from an external antenna, select "TV". If you receive your TV channels from a cable TV system, select "CATV". Place the arrow next to your choice by pressing **CH▲▼** or **PUSH JOG▲▼**, then press **MENU** to return to the Tuner Set screen.

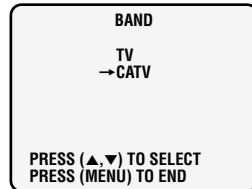

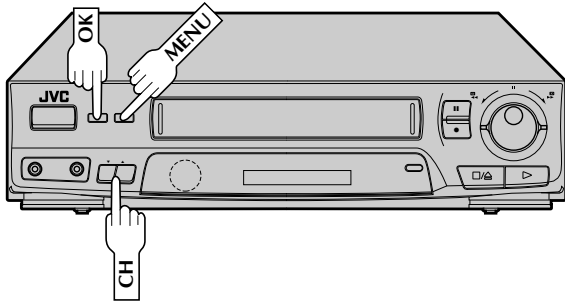

6

PERFORM AUTO CHANNEL SET

Place the arrow next to "AUTO CHANNEL SET" by pressing **CH▲▼** or **PUSH JOG▲▼**, then press **OK**. Receivable channels in your area are automatically assigned to the **CH▲▼** buttons, and non-receivable channels are skipped.

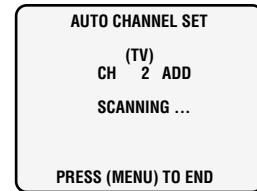

NOTES:

- At the end of Auto Channel Set, "SCAN COMPLETED" appears on screen.
- If the scan was unsuccessful, "SCAN COMPLETED-NO SIGNAL" appears on screen. Check the band setting and connections and start again.

RETURN TO NORMAL SCREEN

7

Press **MENU** as many times as necessary.

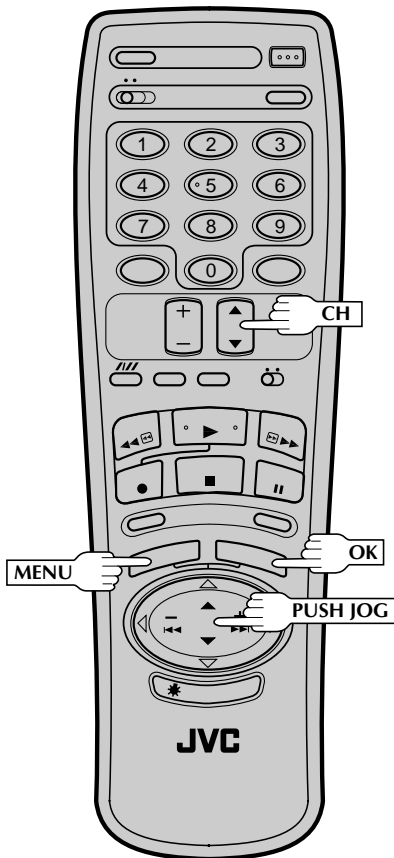

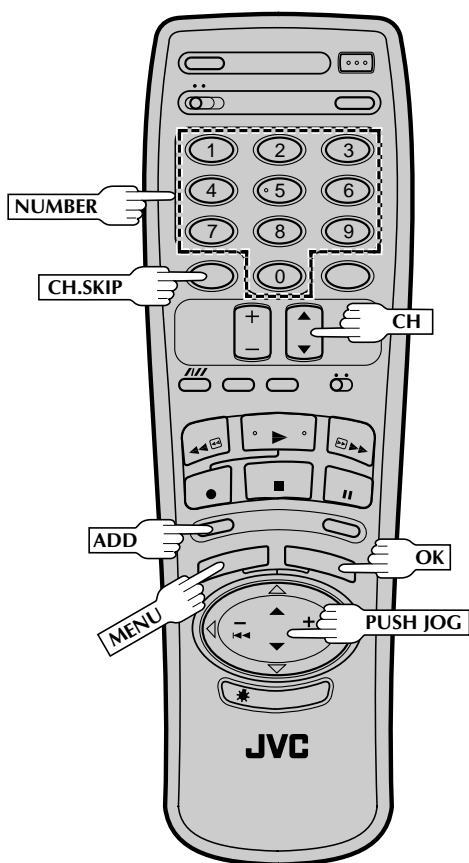
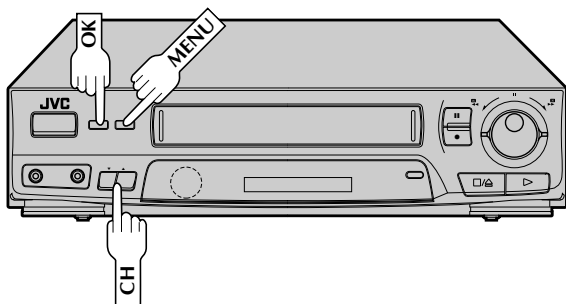

Add Or Delete A Channel

1 ACCESS TUNER SET SCREEN

Access by performing steps 2 and 3 of the Tuner procedure on page 6.

- To add a channel, go to step 2.
- To delete a channel, skip to step 4.

2 ACCESS AFC SCREEN

Place the arrow next to "AFC" by pressing **CH▲▼** or **PUSH JOG▲▼**, then press **OK**.

3 MAKE SELECTION

Place the arrow next to "SPCL" by pressing **CH▲▼** or **PUSH JOG▲▼**, then press **MENU** to return to the Tuner Set screen.

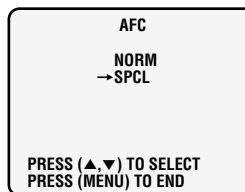

4 ACCESS MANUAL CHANNEL SET SCREEN

Place the arrow next to "MANUAL CHANNEL SET" by pressing **CH▲▼** or **PUSH JOG▲▼**, then press **OK**.

5 STORE DESIRED CHANNEL

Input the channel number by using the **NUMBER** keys or by pressing **CH▲▼** or **PUSH JOG▲▼**, then press **ADD** to add or **CH.SKIP** to delete. Repeat for each channel you want to store or skip.

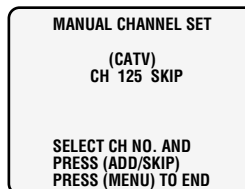

6 RETURN TO NORMAL SCREEN

Press **MENU** as many times as necessary.

G-Code Setup

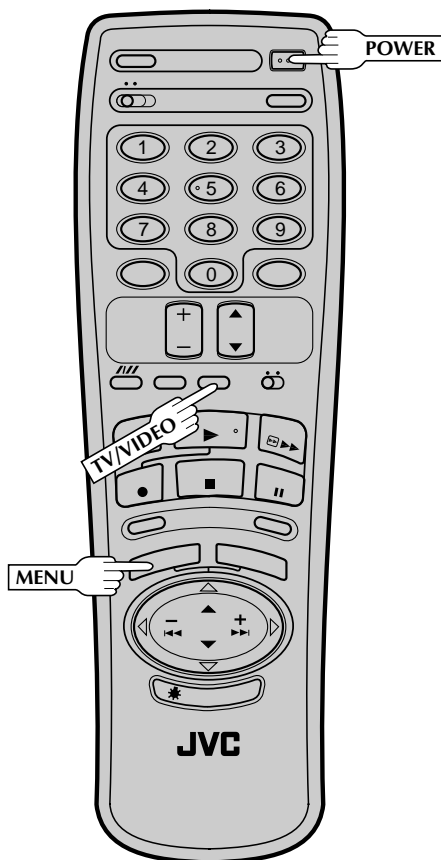
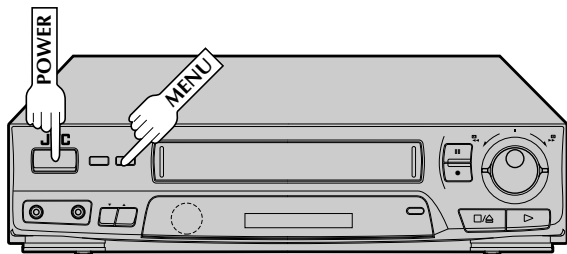

The G-Code timer programming system eliminates the need to input channel, date, start and stop time data when setting the timer record function. Simply key in the G-Code number for the TV program you wish to record (found in most TV listings) and the VCR's timer is automatically programmed.

Depending on the TV or cable stations that you receive and the channel numbers that they are received on in your area, you may have to make certain changes in your VCR's "Guide Channel Set" menu to get proper results. Please read the following information carefully to find out which tasks you need to perform.

Before G-Code setup you must have performed the following procedures:

- Clock setting (☞ pg. 5)
- Tuner setting (☞ pg. 6)

Channel Number Matching

Most TV listings have a chart indicating the "Guide Channel" number assigned to each station for purposes of G-Code programming. Check the chart in your TV listings and see if the Guide Channel numbers listed for the stations you receive are the same as the channel number on which each is received by your VCR.

If the numbers match, go directly to "G-Code Timer Programming" (☞ pg. 26).

If the numbers are different, and you want to be able to timer record programs from those stations, you have to inform the VCR of the mismatch. Go to step 1. If you will not want to timer record from those stations, you can go directly to "G-Code Timer Programming" (☞ pg. 26).

1 TURN ON THE VCR

Press **POWER**. If watching channel 3 or 4, press **TV/VIDEO** to select the TV's VIDEO mode. VIDEO is displayed on the front display panel.

2 ACCESS MAIN MENU SCREEN

Press **MENU** as many times as necessary.

CONTINUED ON NEXT PAGE.

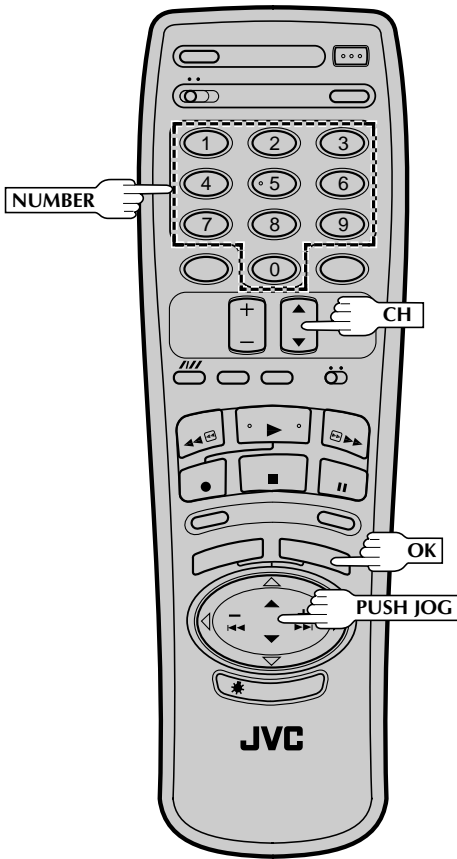
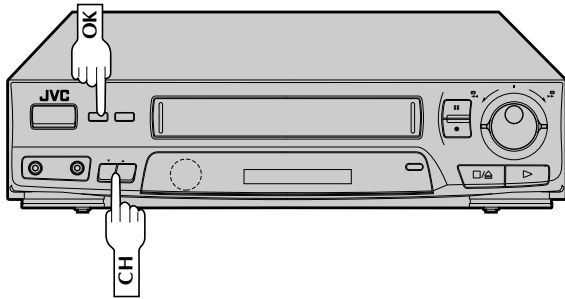

3

ACCESS INITIAL SET SCREEN

Press **CH▲▼** or **PUSH JOG▲▼** to place the arrow next to "INITIAL SET", then press **OK**.

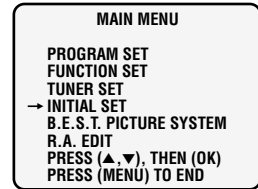

4

ACCESS G-CODE SET-UP SCREEN

Press **CH▲▼** or **PUSH JOG▲▼** to place the arrow next to "G-CODE SET-UP", then press **OK**.



5

ACCESS GUIDE CHANNEL SET SCREEN

Press **CH▲▼** or **PUSH JOG▲▼** to place the arrow next to "GUIDE CHANNEL SET", then press **OK**.



6

INPUT GUIDE CHANNEL NUMBER

Press **CH▲▼** or **PUSH JOG▲▼** or the appropriate **NUMBER** keys to input the Guide Channel number as shown in the TV listing. Then press **OK**.

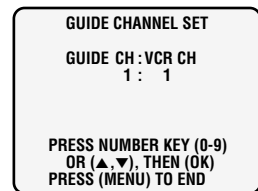

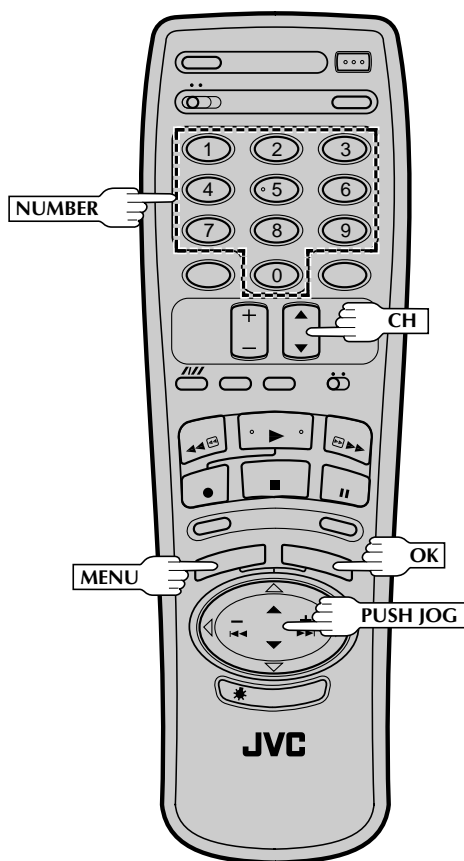
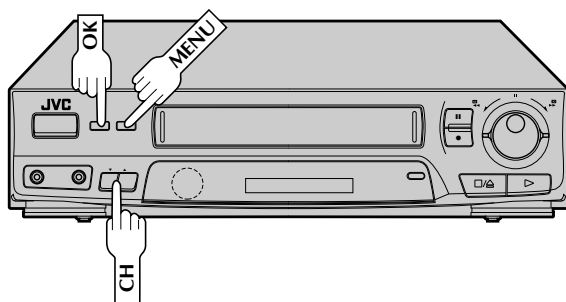

7 INPUT RECEIVING CHANNEL NUMBER

Press **CH▲▼** or **PUSH JOG▲▼** or the appropriate **NUMBER** keys to input the number of the channel on which the Guide Channel's broadcasts are received. Then press **OK**.

- If there is more than one mismatch, repeat steps 6 and 7 for each instance.

8 RETURN TO G-CODE SET-UP SCREEN

Press **MENU**.

9 CHECK INPUT DATA

Press **CH▲▼** or **PUSH JOG▲▼** to place the arrow next to "GUIDE CHANNEL MAP", then press **OK**.

- The Guide Channel and VCR channel numbers you input appear on the screen in ascending order. Check to ensure you've entered them correctly.
- If you entered more than 10 sets of numbers, press **OK** to see the next set of numbers.

G-CODE SET-UP

GUIDE CHANNEL SET
→GUIDE CHANNEL MAP

PRESS (▲,▼), THEN (OK)
PRESS (MENU) TO END

GUIDE CHANNEL MAP

GUIDE : VCR	GUIDE : VCR
6 : 47	10 : 55
12 : 41	15 : 38
33 : 28	67 : 49

PRESS (OK) TO NEXT
PRESS (MENU) TO END

10 RETURN TO NORMAL SCREEN

Press **MENU** as many times as necessary.

You can now use G-Code for quick and simple timer programming (pg. 26).

Simple Playback

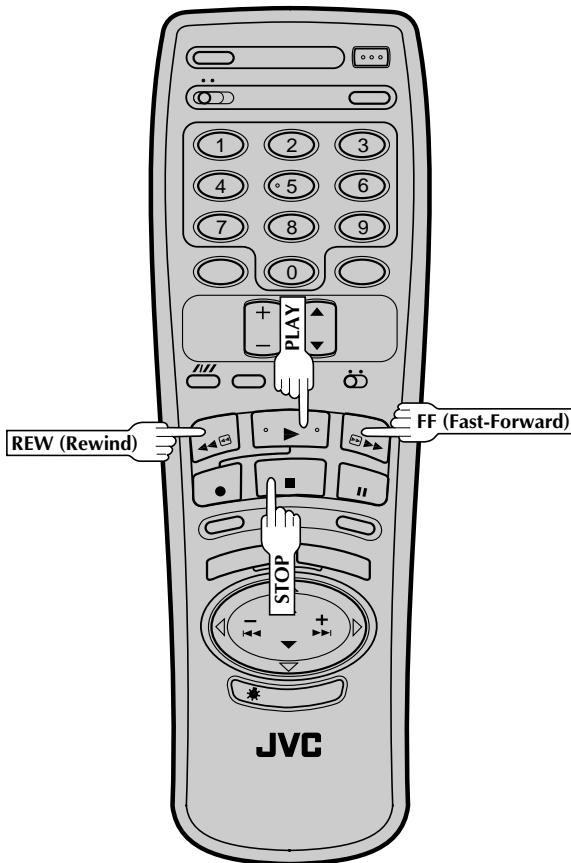
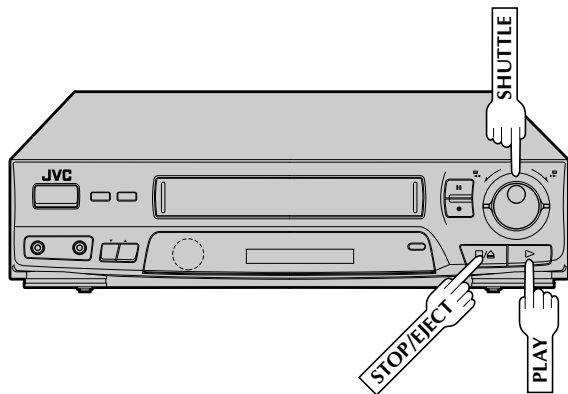

1 LOAD A CASSETTE

Make sure the window side is up, the rear label side is facing you and the arrow on the front of the cassette is pointing towards the VCR. Don't apply too much pressure when inserting.

- The VCR's power comes on automatically.
- The counter is automatically reset to "0H 00M 00S".
- If the cassette's record safety tab has been removed, playback begins automatically.

2 FIND PROGRAM START POINT

If the tape is advanced past the start point, press **REW** or turn the **SHUTTLE** ring to the left and release it. To go forward, press **FF** or turn the **SHUTTLE** ring to the right and release it.

3 START PLAYBACK

Press **PLAY**. "B.E.S.T. PICTURE SYSTEM" appears on screen (see pg. 23).

4 STOP PLAYBACK

Press **STOP** or **STOP/EJECT**. Then press **STOP/EJECT** to remove the cassette.

Usable cassettes

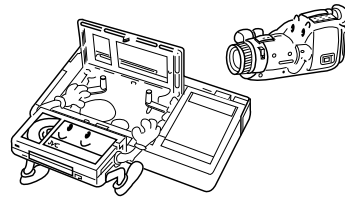

- Compact VHS camcorder recordings can be played on this video recorder. Simply place the recorded cassette into a VHS Cassette Adapter and it can be used just like any full-sized VHS cassette.
- This video recorder can record on regular VHS and Super VHS cassettes. However, it will record and play back regular VHS signals only. It is not possible to play back Super VHS recordings.

Simple Recording

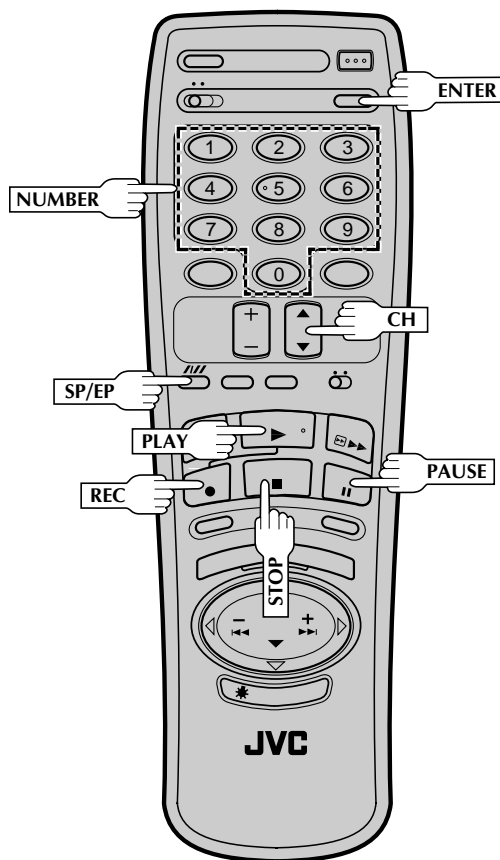
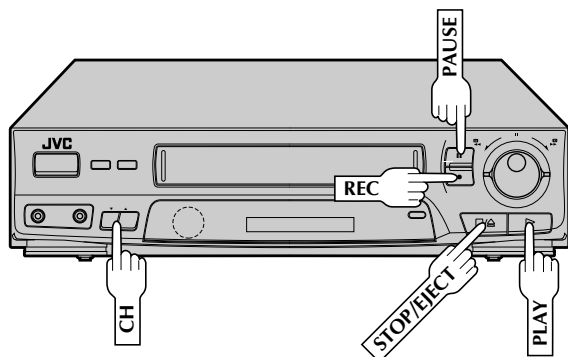

1 LOAD A CASSETTE

Make sure the record safety tab is intact. If not, cover the hole with adhesive tape before inserting the cassette.

2 SELECT RECORDING CHANNEL

Press **CH▲▼**. Or press the appropriate **NUMBER** keys, then press **ENTER**. (The channel changes after a few seconds whether you press **ENTER** or not.)

3 SET TAPE SPEED

Press **SP/EP** to set the recording speed.

4 START RECORDING

Press and hold **REC** and press **PLAY** on the remote control, or press **REC** on the VCR's front panel.

B.E.S.T. takes place at the beginning of both the first SP and the first EP recording after inserting the cassette (see pg. 22).

5 PAUSE/RESUME RECORDING

Press **PAUSE**. Press **PLAY** to resume recording.

6 STOP RECORDING

Press **STOP** or **STOP/EJECT**. Then press **STOP/EJECT** to remove the cassette.

Accidental erasure prevention

- To prevent accidental recording on a recorded cassette, remove its record safety tab. To record on it later, cover the hole with adhesive tape.

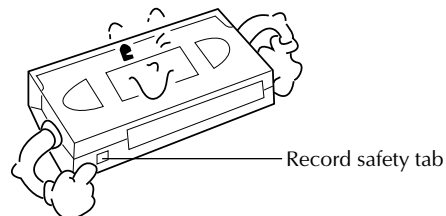

Playback

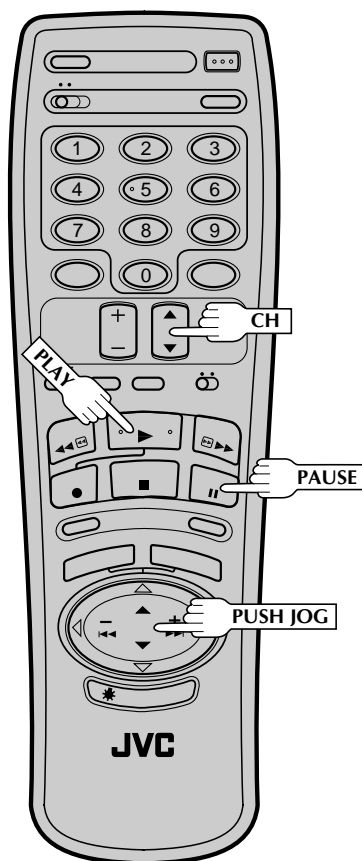
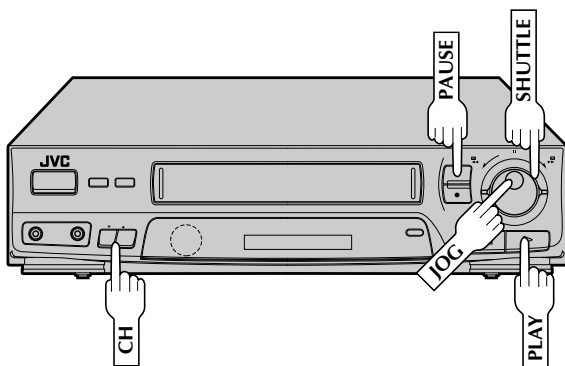

Take advantage of special functions possible with the recorder's controls or the remote control.

NOTE:

Refer to the **SHUTTLE** ring illustration below as you read the following procedures.

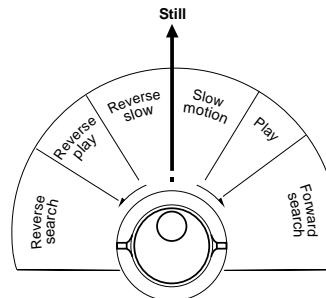

Still Picture/Frame-By-Frame Playback

1 PAUSE DURING PLAYBACK

Press **PAUSE**. If there is vertical jitter, use the **CH ▲** or **▼** button to correct the picture.

2 ACTIVATE FRAME-BY-FRAME PLAYBACK

Turn the **JOG** dial to the right for forward frame-by-frame playback, or to the left for reverse frame-by-frame playback.

OR

Press **PAUSE**.

OR

Press **PUSH JOG** **◀◀** or **▶▶**.

To resume normal playback, press **PLAY**.

Slow Motion/ Reverse Slow Motion

1 ACTIVATE SLOW-MOTION PLAYBACK

During playback or still, turn the **SHUTTLE** ring to the right for forward slow motion, or to the left for reverse slow motion (refer to the illustration above).

OR

During still picture, press and hold **PUSH JOG** **◀◀** or **▶▶**. Release to return to still picture.

To resume normal playback, press **PLAY**.

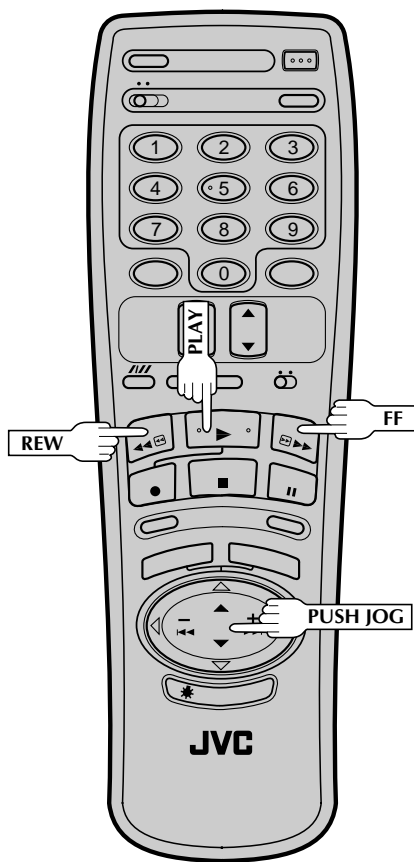
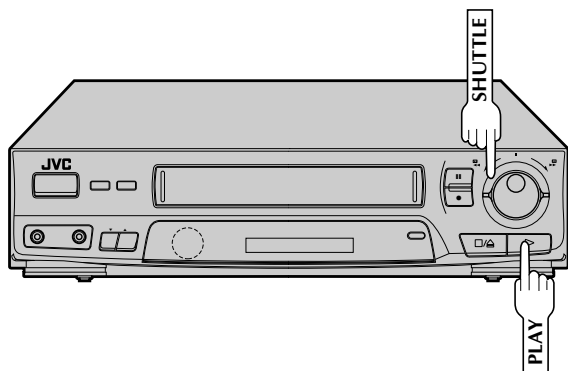

Variable-Speed Search/ Reverse Play

1 ACTIVATE VARIABLE-SPEED SEARCH

During playback or still, turn the **SHUTTLE** ring to the right for forward variable-speed search, or to the left for reverse variable-speed search (refer to the illustration on page 14).

OR

During playback, press **PUSH JOG** ◀◀ or ▶▶.

- To increase the speed in the forward direction, press ▶▶.
- To decrease the speed in the forward direction, press ◀◀.
- To play in reverse slow motion, and in reverse play mode, continue to press ◀◀ after selecting all the forward slow motion modes.

To resume normal playback, press **PLAY**.

High-Speed Search

1 ACTIVATE HIGH-SPEED SEARCH

During playback or still, turn the **SHUTTLE** ring all the way to the right for forward high-speed search, or to the left for reverse high-speed search.

- For forward search with a visible picture, during playback or still turn the **SHUTTLE** ring all the way to the right and release it within 1 second.
- For reverse search with a visible picture, during playback or still turn the **SHUTTLE** ring all the way to the left and release it within 1 second.

OR

During playback or still press **FF** for forward high-speed search, or **REW** for reverse high-speed search.

To resume normal playback, press **PLAY**.

NOTE:

For short searches, during playback or still press and hold **FF** or **REW** for over 2 seconds. When released, normal playback resumes.

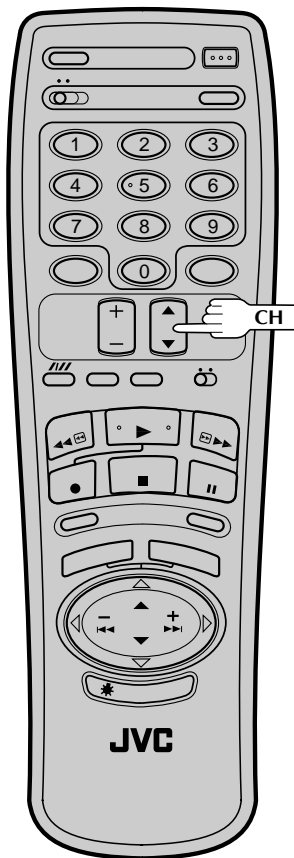
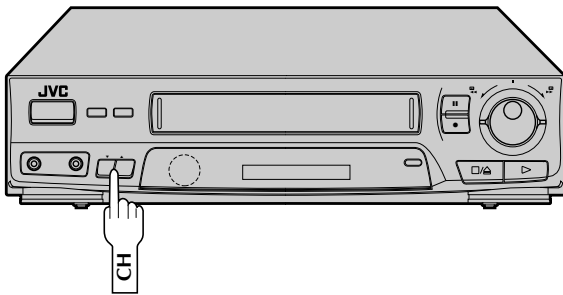

Manual Tracking

Once playback begins, the VCR's automatic tracking function is engaged. If noise appears in the picture, you can override this and make the adjustment manually.

1 ENGAGE MANUAL TRACKING MODE

During playback, press the **CH▲▼** buttons on the VCR's front panel simultaneously to cancel the automatic tracking mode and enable manual tracking adjust.

2 ADJUST MANUAL TRACKING

Press **CH▲▼** on the VCR's front panel or remote. Press lightly for fine adjust, or press and hold for coarse adjust. Watch the screen and continue adjusting until optimum picture and sound quality are achieved.

3 RE-ENGAGE AUTOMATIC TRACKING

Press the **CH▲▼** buttons on the VCR's front panel simultaneously.

- When automatic tracking is re-engaged, video calibration is automatically activated.

NOTE:

During slow-motion playback, simply press **CH▲** or **▼** on the VCR's front panel or remote to adjust tracking.

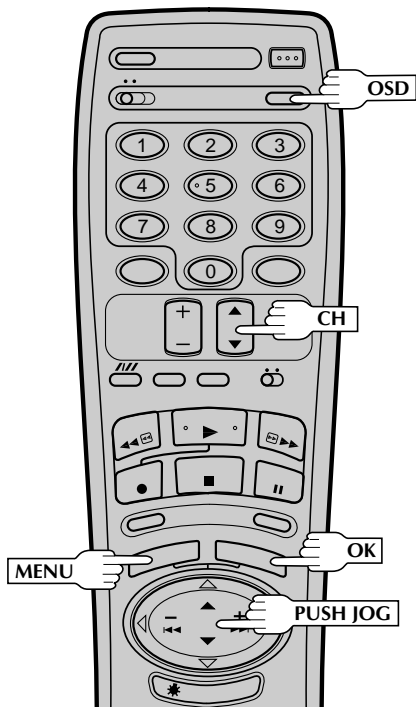
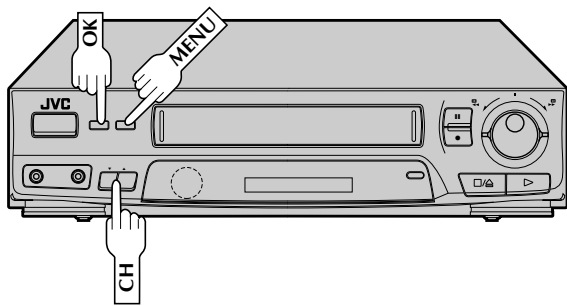

To recall an indication

- 1 Press **OSD**.
 - All indications corresponding to the current status are displayed for 5 seconds, leaving the counter information, and RECORD/PAUSE if in the Record Pause mode, on the screen. (No indication during still and search.)
- 2 Press **OSD** again to clear the display.

Superimpose

This function, switchable between ON and OFF, determines whether or not operational indicators will appear on screen.

1

ACCESS MAIN MENU SCREEN

Press **MENU** as many times as necessary.

2

ACCESS FUNCTION SET SCREEN

Place the arrow next to "FUNCTION SET" by pressing **CH▲▼** or **PUSH JOG▲▼**, then press **OK**.

3

ACCESS SUPERIMPOSE SCREEN

Place the arrow next to "SUPERIMPOSE" by pressing **CH▲▼** or **PUSH JOG▲▼**, then press **OK**.

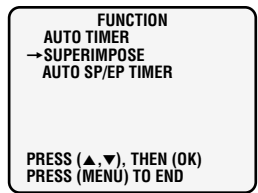

4

SELECT MODE

Place the arrow next to "ON" or "OFF" by pressing **CH▲▼** or **PUSH JOG▲▼**.

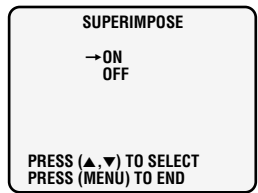

5

RETURN TO NORMAL SCREEN

Press **MENU** as many times as necessary.

NOTE:

If you engage the Record Pause mode, RECORD/PAUSE is displayed whether "SUPERIMPOSE" is set to "ON" or "OFF".

The superimposed indication on the TV screen tells you what the VCR is doing.

- Tuned-in channel or AUX(iliary) mode**
 When the channel is changed, the new channel is displayed on the screen for 5 seconds.
- Clock time**
- Tape position indicator**
- "Cassette Loaded" mark**
 When a cassette is loaded, the mark is displayed for 5 seconds. It blinks when the VCR's EJECT button is pushed.

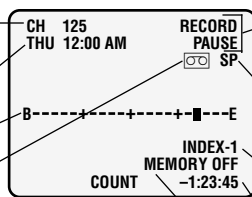

- Operation mode**
 When the operation mode is changed, the new mode is displayed — RECORD (5 sec.), PLAY (5 sec.), FF/REW (5 sec. when engaged from Stop mode), RECORD PAUSE (for as long as Pause is engaged), and ITR *.* (5 sec.).
- Tape speed indicator**
- INDEX indication**
- Counter reading**
- Counter memory on/off**

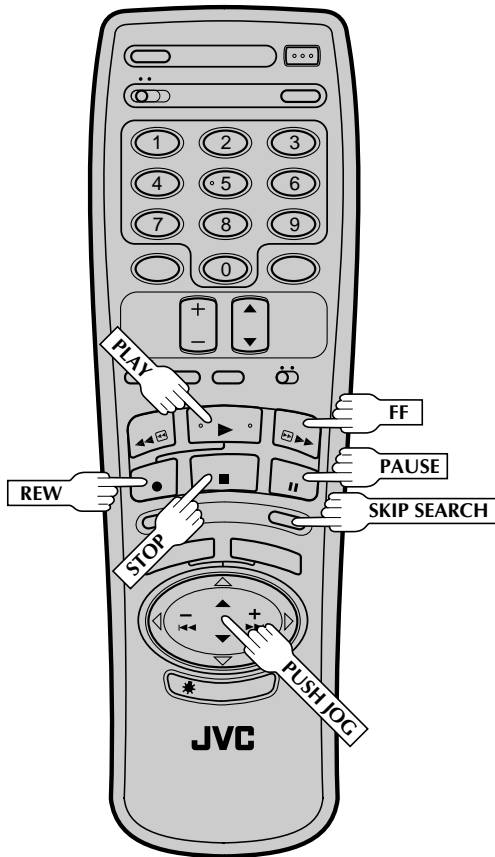
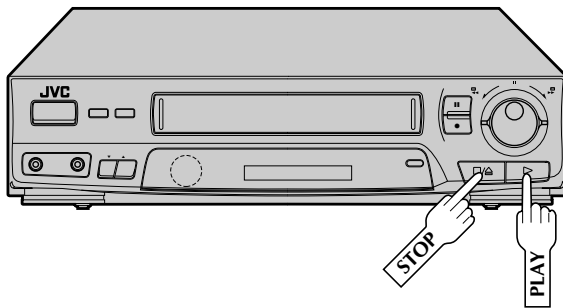

Skip Search

1 SKIP OVER UNWANTED SECTIONS

Press **SKIP SEARCH** 1 to 4 times during playback. Each press initiates a 30-second period of fast-motion playback. Normal playback resumes automatically.

NOTE:

To return to normal playback during a Skip Search, press **PLAY**.

Repeat Playback

1 START REPEAT

Press and hold **PLAY** (until "PLAY" blinks on the front display panel) during playback, then release.

- The entire tape is played back 20 times.

2 STOP REPEAT

To stop, press **STOP** at any time.

NOTE:

Pressing **PLAY**, **REW**, **FF**, **PAUSE** or **PUSH JOG** ◀◀ or ▶▶ also stops Repeat Playback.

Index Search

This function seeks out index codes that are placed on the tape at recording start.

1 START SEARCH

While the tape is stopped, press **PUSH JOG** ◀◀ or ▶▶.

2 ACCESS DISTANT CODE

To access a recording 2–9 index codes away, press **PUSH JOG** ◀◀ or ▶▶ repeatedly until the correct number is displayed on screen (only if **SUPERIMPOSE** is set to ON (pg. 17)). Playback begins automatically when desired recording is located.

- To find the very beginning of the desired program, press **REW** or **FF** and search visually for the start point.

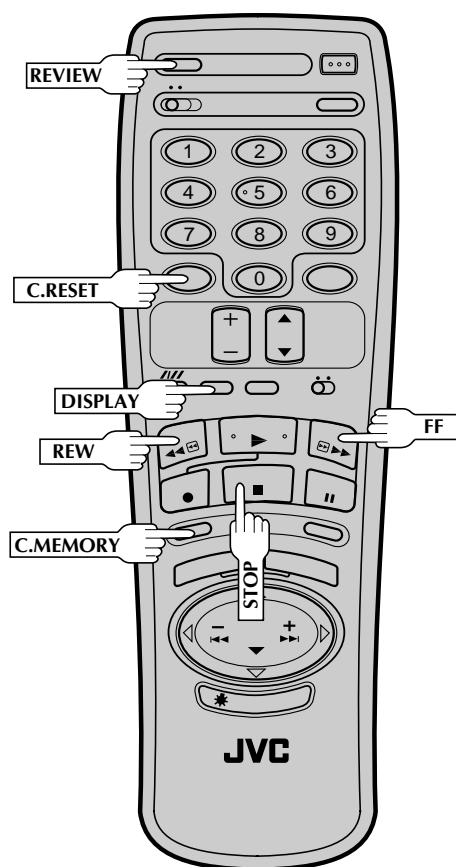
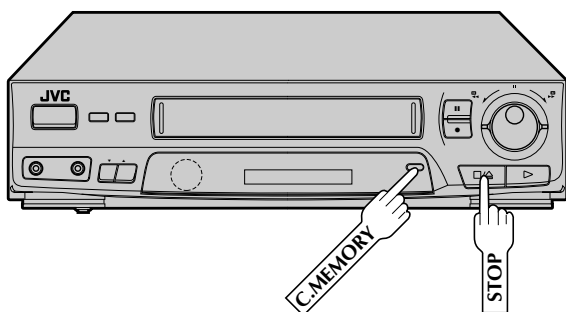

Instant ReView

At the press of a button, you can power up your VCR, rewind the tape and begin viewing the most recent timer-recorded program.

1 ACTIVATE INSTANT REVIEW

After ensuring that the VCR is off and the Timer mode is disengaged, press **REVIEW**.

- The power comes on and the VCR searches for the index code indicating the start of the last timer-recorded program, then begins playback automatically.
- You can access a program 2–9 index codes away from the current position on the tape. If, for example, you have 5 programs recorded and you want to watch the third one, press **REVIEW** three times.
- To find the very beginning of the desired program, press **REW** or **FF** and search visually for the program's start point.

Counter Reset

1 RESET COUNTER TO ZERO

Press **C.RESET**.

NOTE:

By pressing the **DISPLAY** button, you can change the display to show the counter reading, channel number or clock time. (Channel number is not displayed during playback.)

Counter Memory

When activated, this feature returns the tape to counter position "zero".

1 ACTIVATE COUNTER MEMORY

Press **C.RESET** during playback at a point you want to have quick access to later. The counter reads "0H 00M 00S".

Then press **C.MEMORY**. The Counter Memory indicator in the front display panel lights.

2 RETURN TO COUNTER POSITION ZERO

Press **STOP** (during playback), then press **REW**. The tape rewinds and stops at approximately "0H 00M 00S" automatically.

- To cancel Counter Memory, press **C.MEMORY**.

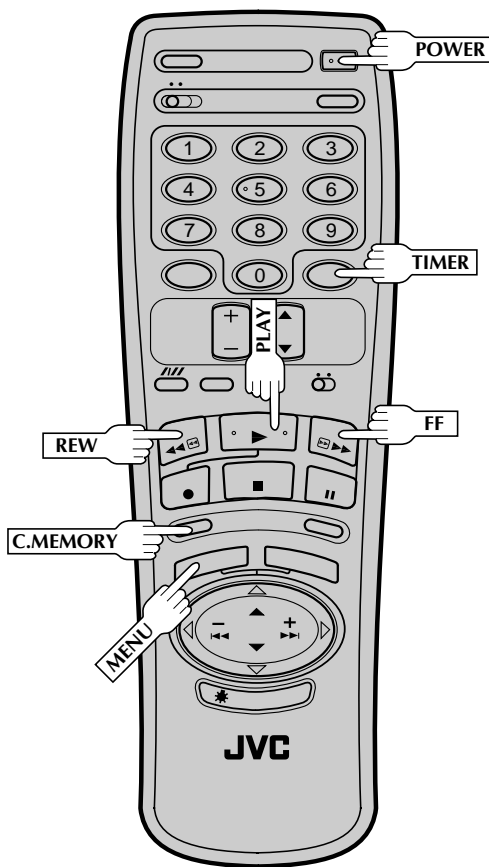
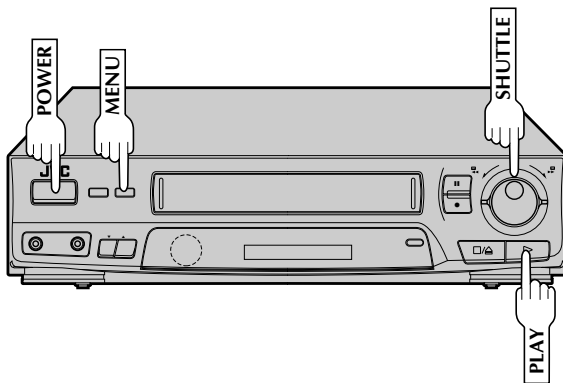

Tape Position Indicator

The Tape position indicator appears on screen when, from the stop mode, you press **FF**, **REW** or perform an Index Search or Instant ReView. The position of "■" in relation to "B" (Beginning) or "E" (End) shows you where you are on the tape.

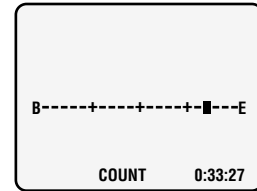

NOTE:

SUPERIMPOSE must be set to **ON**, or the indicator will not appear (☞ pg. 17).

Next-Function Memory

The Next Function Memory "tells" the VCR what to do after rewinding.

- * Before continuing, ensure that the VCR is in stop mode.
- a- For Automatic Start Of Playback After Tape Rewind . . .
 . . . press **REW**, then press **PLAY** within 2 seconds.
- b- For Automatic Power Off After Tape Rewind . . .
 . . . press **REW**, then press **POWER** within 2 seconds.
- c- For Automatic Timer Standby After Tape Rewind . . .
 . . . press **REW**, then press **TIMER** within 2 seconds.

NOTES:

- To do the above using the VCR's controls:
 During Stop, turn the **SHUTTLE** all the way to the left and release it instead of pressing **REW**, and then press **PLAY** or **POWER** within 2 seconds.
- If you want the "next function" to automatically start when the counter reads "0H 00M 00S" (instead of at the beginning of the tape), press **C. MEMORY** so that the counter memory indicator appears on the front display panel before pressing **REW**.

B.E.S.T. Picture System

Your VCR is equipped with the B.E.S.T. (Biconditional Equalized Signal Tracking) feature, which checks the condition of the tape in use during recording and playback, and compensates to provide the highest-possible recording and playback pictures.
*The default setting for both recording and playback is "ON".

Preparation

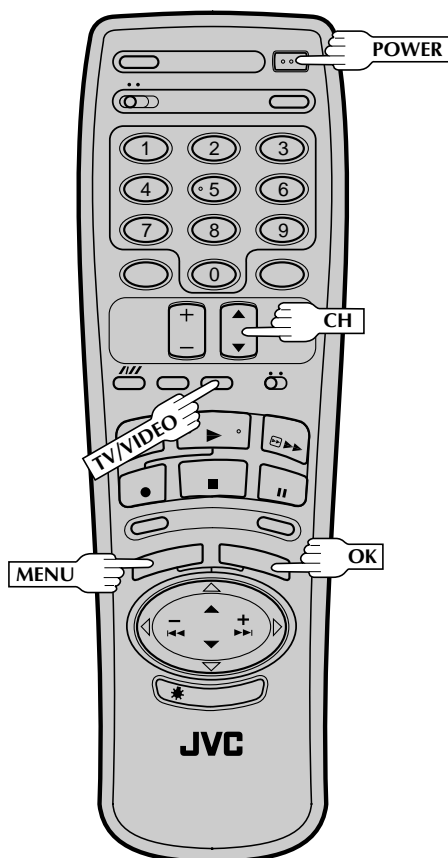
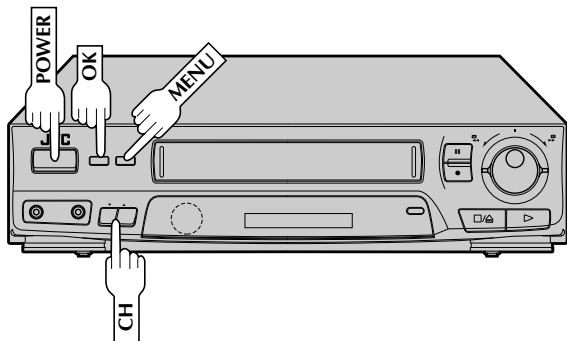

1 TURN ON THE VCR

Press **POWER**. If watching channel 3 or 4, press **TV/VIDEO** to select the VIDEO mode. VIDEO is displayed on the front display panel.

2 ACCESS MAIN MENU SCREEN

Press **MENU** as many times as necessary.

3 ACCESS B.E.S.T. PICTURE SYSTEM SCREEN

Press **CH▲▼** or **PUSH JOG▲▼** to place the arrow next to "B.E.S.T. PICTURE SYSTEM", then press **OK**.

MAIN MENU	
PROGRAM SET	
FUNCTION SET	
TUNER SET	
INITIAL SET	
→ B.E.S.T. PICTURE SYSTEM	
R.A. EDIT	
PRESS (▲,▼), THEN (OK)	
PRESS (MENU) TO END	

4 SELECT MODE

Place the arrow next to "ON" by pressing **CH▲▼** or **PUSH JOG▲▼**, then press **OK** to move the arrow to the Playback section. Set Playback to "ON", then press **MENU** as many times as necessary to return to the normal screen. (Pressing **OK** returns the arrow to the Recording section.)

B.E.S.T. PICTURE SYSTEM	
RECORDING	→ ON OFF
PLAYBACK	→ ON OFF
PRESS (▲,▼), THEN (OK)	
PRESS (MENU) TO END	

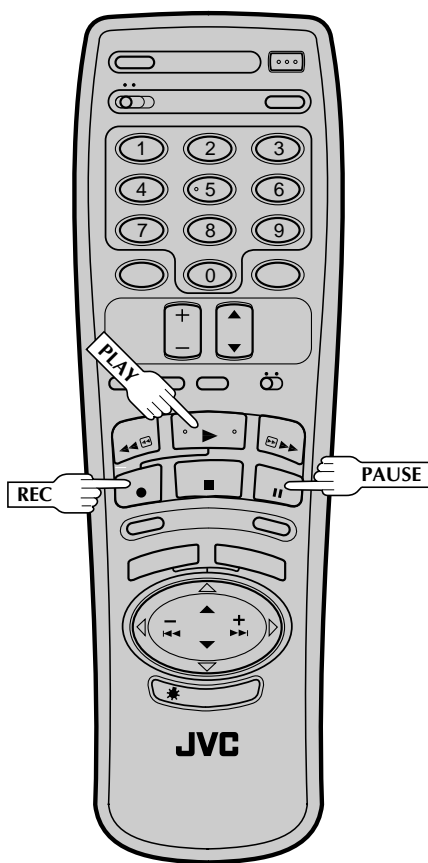
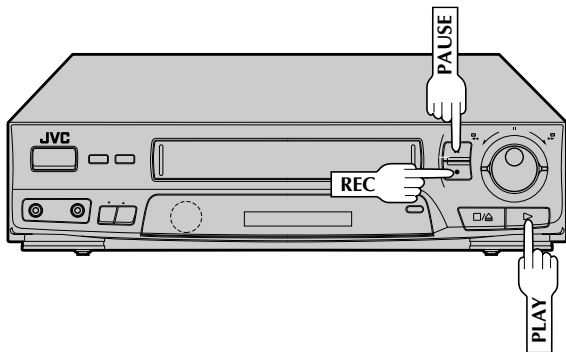

Recording

Perform steps 1 – 3 on page 13 ("Simple Recording") before continuing.

1

START RECORDING

Press and hold **REC** and press **PLAY** on the remote control, or press **REC** on the VCR's front panel.

- The VCR takes about 7 seconds to assess the quality of the tape in use, then recording begins with the picture level optimized.

DURING B.E.S.T.

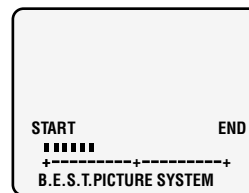

B.E.S.T. COMPLETE

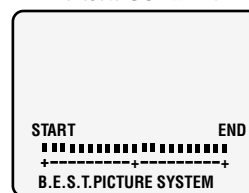

NOTES:

- *B.E.S.T.* occurs immediately prior to both the first *SP* and the first *EP* recording after inserting the cassette. It does not take place during recording.
- In the case of timer recording, *B.E.S.T.* takes place for both *SP* and *EP* before the first timer recording after inserting the cassette (regardless of the tape speed selected for that recording).
- Once the cassette is ejected, the *B.E.S.T.* data is canceled. The next time the cassette is used for recording, *B.E.S.T.* is re-performed.
- While *B.E.S.T.* is operative, the **PAUSE** button will not function.
- *SUPERIMPOSE* must be set to "ON" or the *B.E.S.T.* Picture System screen will not appear (☞ pg. 17).

ATTENTION:

- As *B.E.S.T.* takes place before recording actually starts, there is a delay of about 7 seconds after **REC** and **PLAY** on the remote, or **REC** on the VCR's front panel, are pressed. To make sure you record the desired scene or program completely, first perform the following steps:
 - 1) Press and hold **PAUSE**, and press **REC** to engage the RECORD PAUSE mode.
 - The VCR then automatically checks the condition of the tape and, after about 7 seconds, re-enters RECORD PAUSE.
 - 2) Press **PLAY** to start recording.
 - If you want to bypass *B.E.S.T.* and start recording right away, set "RECORDING" to "OFF" in step 4 of the Preparation procedure (☞ pg. 21).

Playback

The VCR assesses the quality of the tape once you initiate playback.

Before beginning, perform steps 1 and 2 on page 12.

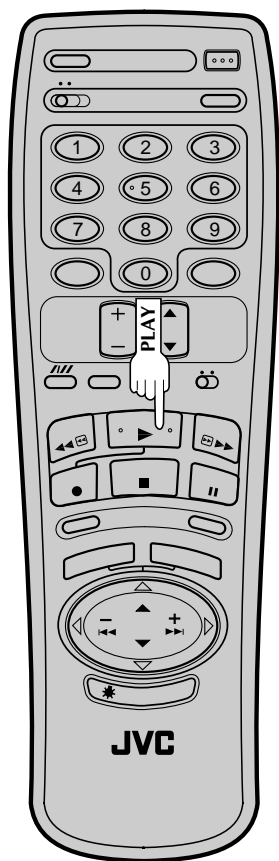
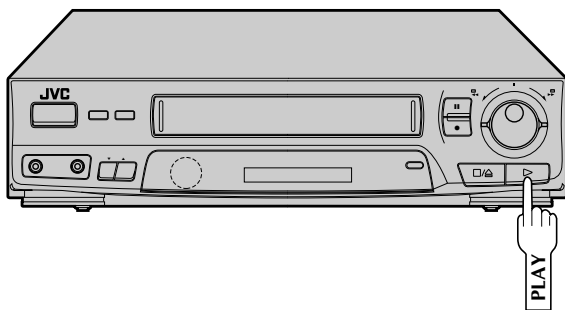

1 START PLAYBACK

Press **PLAY**.

- The VCR adjusts the playback picture quality based on the quality of the tape in use.

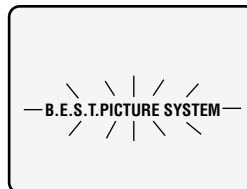

NOTES:

- When using rental tapes, or tapes recorded on other VCRs, set "PLAYBACK" in step 4 of the Preparation procedure to either "ON" or "OFF" as desired (pg. 21).
- The B.E.S.T. Picture System screen only appears at the beginning of automatic tracking. Even though the screen doesn't appear after that, the B.E.S.T. function is operative.
- SUPERIMPOSE must be set to "ON" or the B.E.S.T. Picture System screen will not appear (pg. 17).

Recording

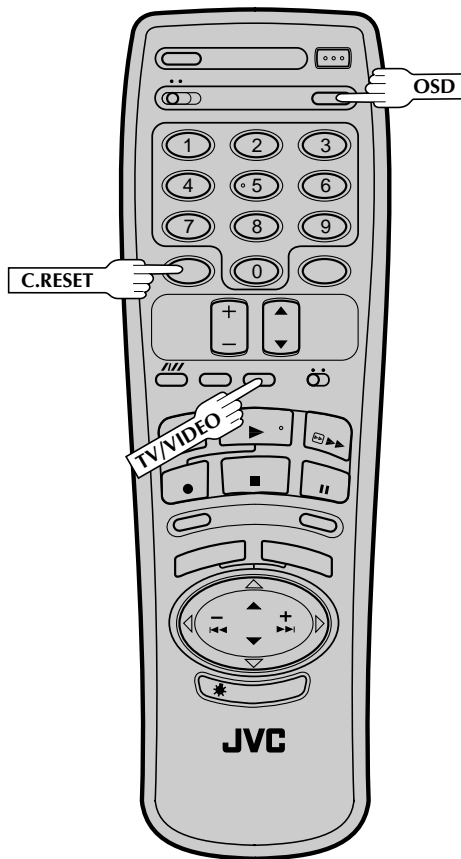
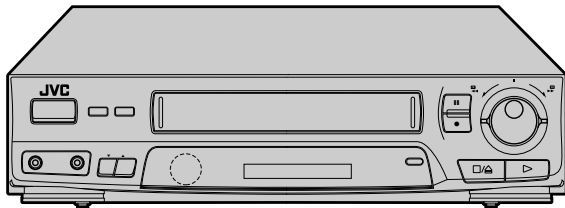

Record One Program While Watching Another

1 ENGAGE TV MODE

During recording...

- If using the RF connection (☞ pg. 4), press **TV/VIDEO**. The VCR's VIDEO indicator goes out and the TV broadcast being recorded disappears.
- If using the AV connection (☞ pg. 4), change the TV's input mode from AV to TV.

2 SELECT CHANNEL FOR VIEWING

Use the TV's channel selector to set the channel you want to watch.

Display Elapsed Recording Time

1 RESET COUNTER TO ZERO

Before recording starts, press **C.RESET**. The counter resets to zero and displays the exact elapsed time as the tape runs.

2 DISPLAY ELAPSED TIME ON SCREEN

During recording, press **OSD** at any time to see the elapsed time. All indications corresponding to the current status of the VCR are displayed for 5 seconds. The counter display remains on the screen indicating the elapsed time. Press **OSD** again to remove the display.

- Make sure "SUPERIMPOSE" is set to "ON" (☞ pg. 17).

Instant Timer Recording (ITR)

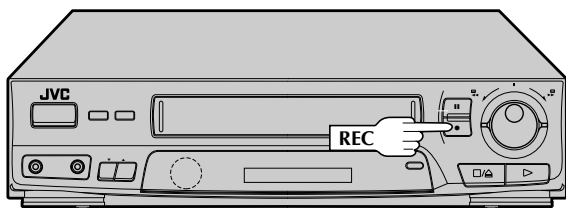

This easy method lets you record for from 30 minutes to 6 hours (selectable in 30-min. increments), and shuts the VCR off after recording is finished.

1 START RECORDING

Press **REC**.

2 ENGAGE ITR MODE

Press **REC** again. ITR blinks and 0:30 appears on the front display panel.

3 SET RECORDING DURATION

If you want to record for more than 30 minutes, press **REC** to extend the time. Each press extends recording time by 30 minutes.

NOTES:

- You can only perform ITR using the **REC** button on the VCR's front panel.
- After you set the time, the previous display reappears.
- To check remaining recording time, press **REC** once during recording and the remaining time is displayed for about 5 seconds. Be careful not to press again during this 5 seconds, or you'll add 30 more minutes to the recording.

G-Code Timer Programming

Before G-Code Timer programming, see "G-Code Setup" on page 9.

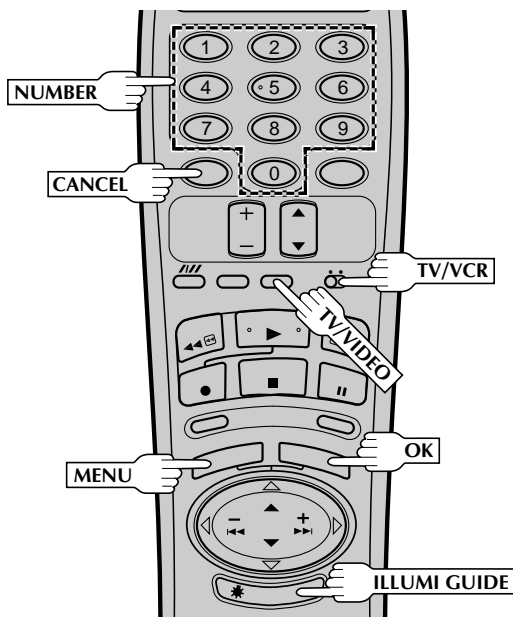
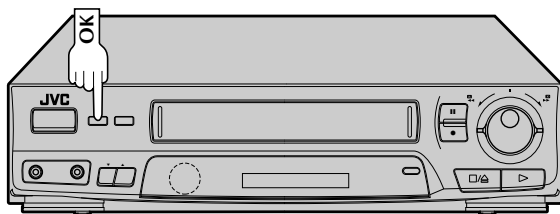

When Using The Illumi-Guide Feature

- Buttons light or blink on the remote control for approximately 10 seconds. If the button or buttons extinguish during timer programming, press **ILLUMI GUIDE** and the button or buttons previously lit or blinking come back on. If the button or buttons do not re-light or start blinking again, press **MENU** as many times as necessary to return to the normal screen and extinguish all illuminated buttons, and re-perform the timer programming procedure from the beginning.
- If for some reason the remote control's signal is not received by the VCR, press **MENU** as many times as necessary to return to the normal screen and extinguish all illuminated buttons, and re-perform the timer programming procedure from the beginning.

During G-Code and on-screen timer programming, the Illumi-Guide feature tells you which button on the remote control must be pressed next by lighting it up. To use this feature, with the **TV/VCR** switch set to "VCR", press **ILLUMI GUIDE** before performing step 2. (**MENU**, **REW**, **PLAY**, **FF** light up at this time.)

If you aren't going to use the Illumi-Guide feature, go directly to step 1.

1 LOAD A CASSETTE

Make sure the record safety tab is present.

- The VCR's power comes on automatically.
- If you're watching on channel 3 or 4, press **TV/VIDEO** to select the VIDEO mode. VIDEO is displayed on the front display panel.

2 ACCESS G-CODE SCREEN

Press **MENU** on the remote control.

G-CODE

PRESS NUMBER KEY(0-9)
PRESS (MENU) TO MAIN MENU

- The clock must be set in order to access the G-Code screen. If you haven't set the clock, the Main Menu screen appears when you press **MENU**. Refer to page 5 for the clock setting procedure.
- If you are using the Illumi-Guide feature, **OK** blinks when the following buttons are lit: **NUMBER** keys (0 - 9), **CANCEL** and **MENU**.

3 ENTER G-CODE NUMBER

Press the appropriate **NUMBER** keys to enter the G-Code number printed in the TV listings for the TV program you wish to record.

- To make corrections, press **CANCEL** and input the correct G-Code number.
- If the G-Code number you input is incorrect, "ERROR" may appear on the screen to advise you of the error. This happens when the G-Code number is for a program which has already passed. "ERROR" is displayed for about 4 seconds and the G-Code screen reappears (step 2).
- If you are using the Illumi-Guide feature, **OK** blinks when the following buttons are lit: **NUMBER** keys (0 - 9), **CANCEL** and **MENU**.

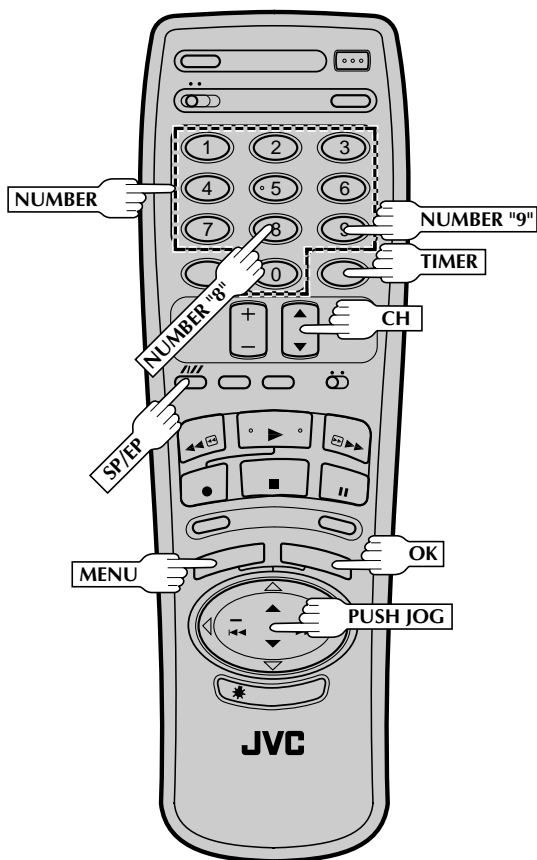
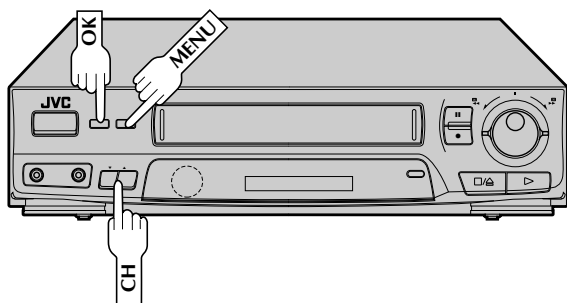

4 CHECK INPUT DATA

Press **OK** and the Program screen appears. The G-Code number you entered appears in the Program screen. Check to make sure it's accurate.

PROGRAM 1	
(G-CODE 12345678)	
DATE	7/10 WED
START	8:00 PM
STOP	9:00 PM
CHANNEL	8 SP
PRESS (8=DAILY, 9=WEEKLY SP/EP=REC SPEED)	
PRESS (MENU) TO END	

- To timer-record daily or weekly serials, press **DAILY** (NUMBER "8") or **WEEKLY** (NUMBER "9"). "DAILY" or "WEEKLY" appears on the Program screen.
- If you made a mistake, press **CANCEL** and, after pressing **MENU** as many times as necessary to access the G-Code screen, input the correct G-Code number.
- If you are using the Illumi-Guide feature, **OK** blinks when the following buttons are lit: **NUMBER** keys (0 - 9), **CANCEL** and **MENU**.

5 SET TAPE SPEED

Press **SP/EP**.

6 CHECK/CORRECT INPUT DATA

If the data is correct as it is, go to step 7. If not, press **OK** or **PUSH JOG** ◀▶▶▶ until the item you want to change begins to blink. Then press the appropriate **NUMBER** keys, **CH**▲▼ or **PUSH JOG** ▲▼ to obtain the desired setting.

- If you are using the Illumi-Guide feature, **OK** blinks when the following buttons are lit: **NUMBER** keys (0 - 9), **CANCEL** and **MENU**.

7 RETURN TO NORMAL SCREEN

Press **MENU** as many times as necessary.

- Press just once to access the Auto Timer screen (pg. 32).
- If you are using the Illumi-Guide feature, all buttons go out.

8 ENGAGE TIMER MODE

Press **TIMER**. The VCR turns off automatically.

NOTES:

- To disengage the timer before recording starts, press **TIMER** again. Pressing once more re-engages it.
- In case of a power failure after programming, the VCR's memory backup keeps your selections for 18 hours.
- Backup time becomes shorter as the unit's internal parts become old. When this occurs, please consult your nearby JVC dealer.

On-Screen Timer Programming

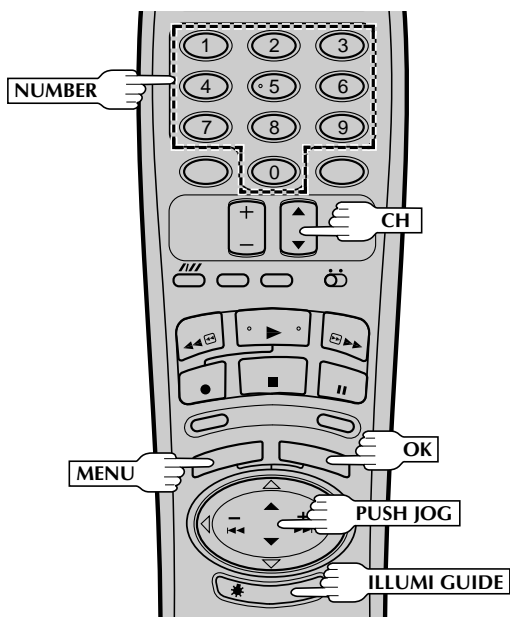
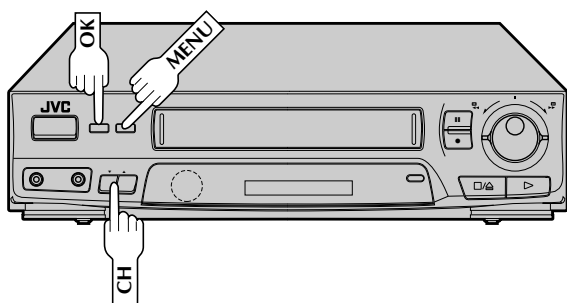

When Using The Illumi-Guide Feature

- Buttons light or blink on the remote control for approximately 10 seconds. If the button or buttons extinguish during timer programming, press **ILLUMI GUIDE** and the button or buttons previously lit or blinking come back on. If the button or buttons do not re-light or start blinking again, press **MENU** as many times as necessary to return to the normal screen and extinguish all illuminated buttons, and re-perform the timer programming procedure from the beginning.
- If for some reason the remote control's signal is not received by the VCR, press **MENU** as many times as necessary to return to the normal screen and extinguish all illuminated buttons, and re-perform the timer programming procedure from the beginning.

You can directly program the VCR's timer to record up to 8 shows, as far as a year in advance. Remember, the clock must be set before you can program the timer (pg. 5). Or you can use the Illumi-Guide feature, where the remote control tells you which button to press next by lighting it up. To use the Illumi-Guide feature, with the TV/VCR switch set to "VCR", press **ILLUMI GUIDE** before performing step 2. (**MENU**, **REW**, **PLAY**, **FF** light up at this time.)

If you aren't going to use the Illumi-Guide feature, go directly to step 1.

1 LOAD A CASSETTE

Make sure the record safety tab is intact. If not, cover the hole with adhesive tape, then load.

- The VCR comes on, and the counter is reset, automatically.
- If watching channel 3 or 4, press **TV/VIDEO** to select the VIDEO mode. VIDEO is displayed on the front display panel.

2 ACCESS ON-SCREEN MENU

Press **MENU** as many times as necessary to bring up the Main Menu screen.

- If you are using the Illumi-Guide feature, **OK** blinks when the following buttons are lit: **NUMBER** keys (0 - 9), **CANCEL** and **MENU**.

3 ACCESS PROGRAM SET SCREEN

Make sure the arrow is to the left of "PROGRAM SET", then press **OK**.

- If you are using the Illumi-Guide feature, **OK** blinks when the following buttons are lit: **NUMBER** keys (0 - 9), **PUSH JOG**, **CANCEL** and **MENU**.

PROGRAM 1	
DATE	--/--
START	--:-- AM
STOP	--:-- AM
CHANNEL	-- SP
PRESS NUMBER KEY(0-9) OR (▲, ▼), THEN (OK) PRESS (MENU) TO END	

4 SELECT PROGRAM NUMBER

Press the appropriate **NUMBER** keys or **CH▲▼** or **PUSH JOG ▲▼** to select a vacant program number, then press **OK**. The first time you do this, all numbers will be vacant, so just press **OK** when the screen appears.

- If you are using the Illumi-Guide feature, **OK** blinks when the following buttons are lit: **NUMBER** keys (0 - 9), **PUSH JOG**, **CANCEL** and **MENU**.

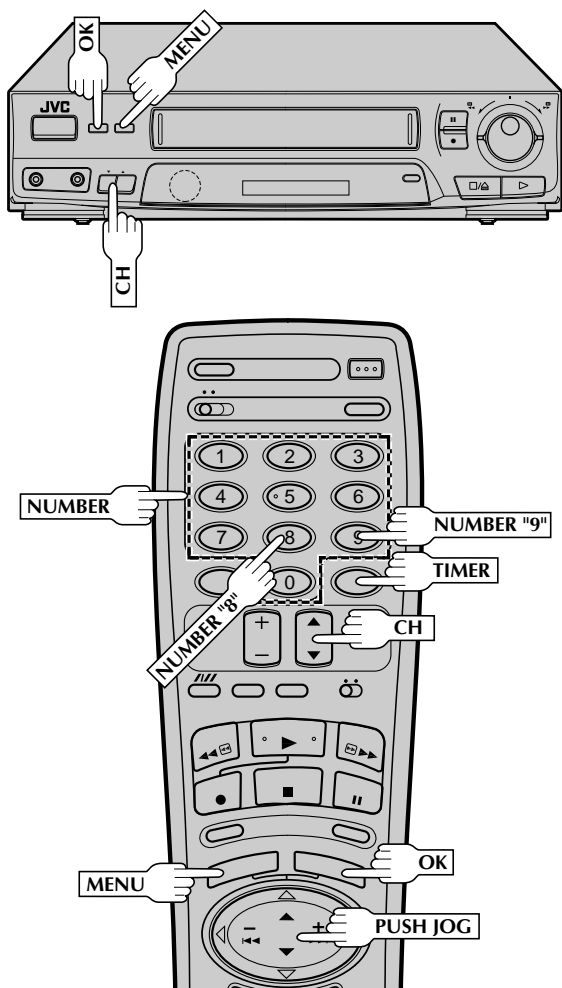
**EXAMPLE**

If you program the VCR to timer record a show on September 6 on channel 40 from 12:00 noon to 1:00 PM in SP mode, the screen will look like this:

PROGRAM 1	
DATE	9/6 FRI
START	12:00 PM
STOP	1:00 PM
CHANNEL	40 SP
PRESS NUMBER KEY(0-9) OR (▲,▼), THEN (OK) PRESS (MENU) TO END	

NOTES:

- To disengage the timer before recording starts, press **TIMER** again. Pressing once more re-engages it.
- In case of a power failure after programming, the VCR's memory backup keeps your selections for 18 hours.
- Backup time becomes shorter as the unit's internal parts become old. When this occurs, please consult your nearby JVC dealer.
- If you select "PROGRAM SET" without having set the date and time, an error message appears. Follow its instructions.

5 SET PROGRAM INFORMATION

Press the appropriate **NUMBER** keys to set the date, start/stop time and channel number. Press **CH▲▼** or **PUSH JOG ▲▼** to set AM/PM and tape speed. Press **OK** after AM/PM, channel number and tape speed settings. The next setting that can be set begins flashing.

- Any information comprised of 1 digit (except the channel number) should have a "0" entered before it.
- It is possible to set all information using the **CH▲▼** or **PUSH JOG ▲▼** button.
(In this case, press **OK** after each setting.) Do not use the **CH ▼** or **PUSH JOG ▼** button to set the date.
- If you are using the Illumi-Guide feature, **OK** blinks when the following buttons are lit: **NUMBER** keys (0 - 9), **PUSH JOG**, **CANCEL** and **MENU**.

** You can record selected programs at the same time every weekday, or once a week. Before entering the month, press **NUMBER** key "8" (DAILY) or "9" (WEEKLY). Either "DAILY" or "WEEKLY" appears. Press again and "DAILY" or "WEEKLY" disappears.

6 MAKE CORRECTIONS

To change any of the settings, press **OK** or **PUSH JOG** ◀▶ until the item you want to change begins blinking. Then set as in step 5.

- If you are using the Illumi-Guide feature, **OK** blinks when the following buttons are lit: **NUMBER** keys (0 - 9), **PUSH JOG**, **CANCEL** and **MENU**.

7 RETURN TO NORMAL SCREEN

Press **MENU** as many times as necessary.

- Press just once to access the Auto Timer screen (pg. 32).
- If you are using the Illumi-Guide feature, all buttons go out.

8 ENGAGE TIMER MODE

Press **TIMER**. The VCR turns off automatically.

- If you enter a start time that has already passed, "ERROR" appears on the screen and flashes.
- Programs that start after midnight must have the next day's date.
- After timer recording is completed, the VCR's power goes off automatically.
- You can program the timer while a regular recording is in progress; the on-screen menu will not be recorded.
- If the end of tape is reached during timer recording, the cassette is automatically ejected.

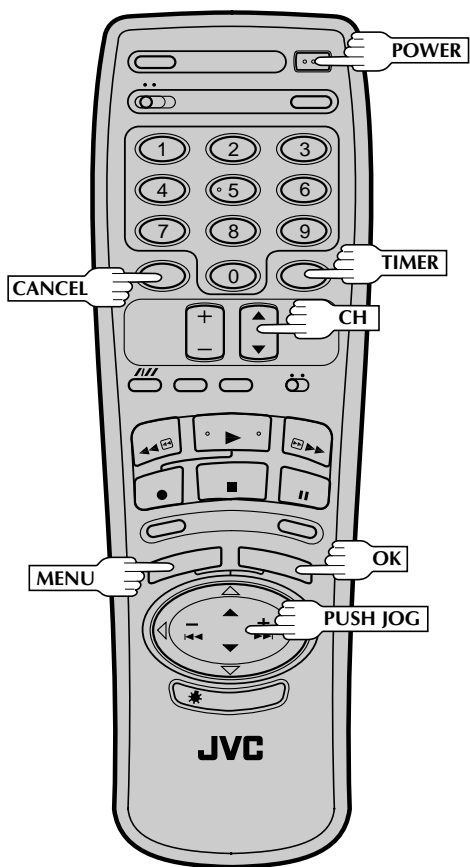
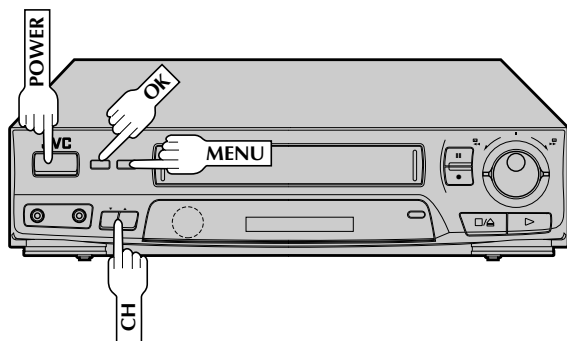

Check And Cancel Programs

1 DISENGAGE TIMER

Press **TIMER**, then press **POWER**.

2 ACCESS MAIN MENU SCREEN

Press **MENU** as many times as necessary.

3 ACCESS PROGRAM SET SCREEN

Press **CH▲▼** or **PUSH JOG▲▼** to place the arrow next to "PROGRAM SET", then press **OK**.

4 CHECK PROGRAM INFORMATION

Press **CH▲▼** or **PUSH JOG▲▼** to check the programs in succession.

To Cancel A Program . . .

5 CANCEL A PROGRAM

Press **CANCEL**.

- Repeat steps 4 and 5 as many times as necessary.

6 RETURN TO NORMAL SCREEN

Press **MENU** as many times as necessary. If there are still programs remaining, go to step 7.

7 RE-ENGAGE TIMER

Press **TIMER** again.

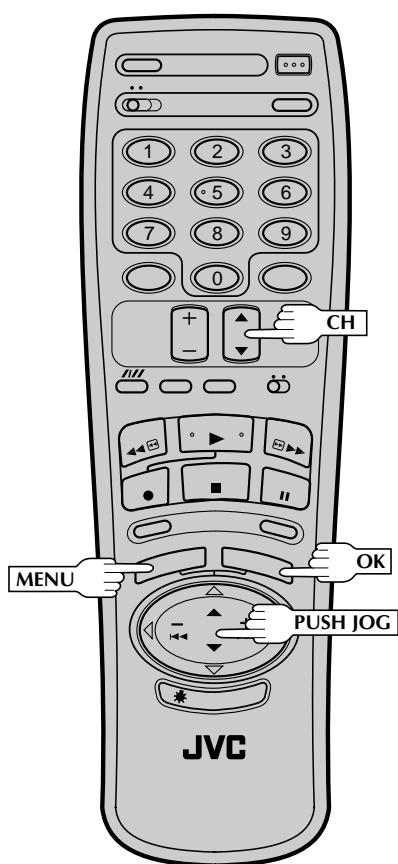
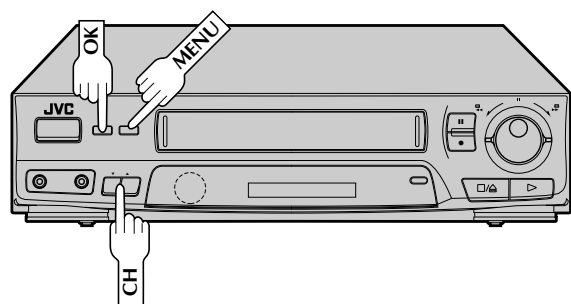

NOTES:

- If you have programmed the VCR to timer-record 2 or more programs, the second program and those thereafter may not fit on the tape if you set the Auto SP/EP Timer mode to "ON". In this case, make sure the mode is not engaged, then set the tape speed manually during timer programming.
- There may be some noise at the point on the tape where the VCR switches from SP to EP mode.
- The Auto SP/EP Timer feature is not available during ITR (Instant Timer Recording), and the feature will not work properly with any tapes other than the following: T-30, T-60, T-90, and T-120.

Auto SP/EP Timer

If, when recording in SP mode, there is not enough tape to record the entire program, the VCR automatically switches to EP mode to allow complete recording. This feature is especially handy when recording a program of more than 2 hours in length.

For Example . . .

Recording a program of 140 minutes in length onto a 120-minute tape

Approximately 110 minutes	Approximately 30 minutes
SP mode	EP mode
Total 140 minutes	

Make sure you select "ON" at the Auto SP/EP Timer screen before performing timer programming.

1 ACCESS MAIN MENU SCREEN

Press **MENU** as many times as necessary.

2 ACCESS FUNCTION SET SCREEN

Place the arrow next to "FUNCTION SET" by pressing **CH▲▼** or **PUSH JOG▲▼**, then press **OK**.

3 ACCESS AUTO SP/EP TIMER SCREEN

Place the arrow next to "AUTO SP/EP TIMER" by pressing **CH▲▼** or **PUSH JOG▲▼**, then press **OK**.

4 SELECT MODE

Place the arrow next to your choice ("ON" or "OFF") by press **CH▲▼** or **PUSH JOG▲▼**.



5 RETURN TO NORMAL SCREEN

Press **MENU** as many times as necessary.

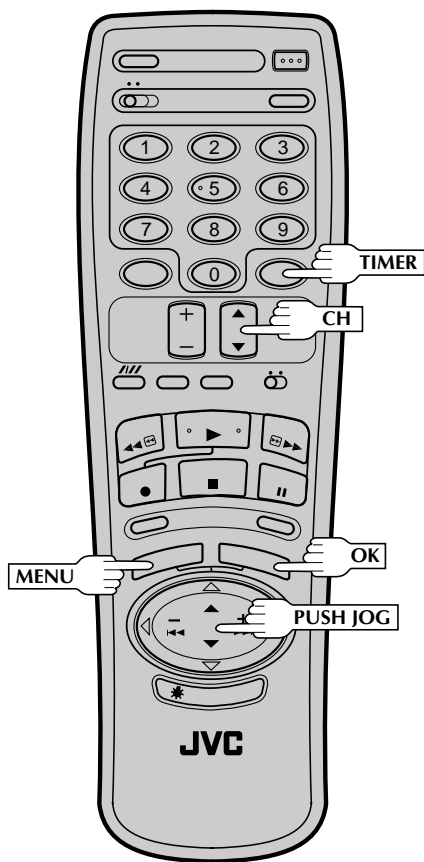
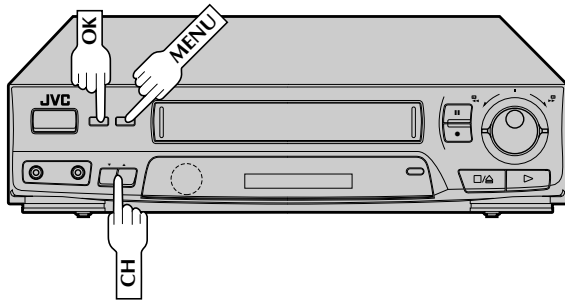

Auto Timer

When the Auto Timer is set to ON the timer is automatically engaged when the VCR's power is turned off and automatically disengaged when the VCR is powered back on.

- 1** ACCESS MAIN MENU SCREEN
Press **MENU** as many times as necessary.
- 2** ACCESS FUNCTION SET SCREEN
Place the arrow next to "FUNCTION SET" by pressing **CH▲▼** or **PUSH JOG▲▼**, then press **OK**.
- 3** ACCESS AUTO TIMER SCREEN
Place the arrow next to "AUTO TIMER" by pressing **CH▲▼** or **PUSH JOG▲▼**, then press **OK**. Now skip to step 2 of the procedure below.

Or, during on-screen timer programming ...

- 1** ACCESS AUTO TIMER SCREEN
In step 7 in the G-Code Timer Programming procedure (pg. 27) or in step 7 in the On-Screen Timer Programming procedure (pg. 29), press **MENU**.
- 2** SELECT MODE
Place the arrow next to your choice ("ON" or "OFF") by pressing **CH▲▼** or **PUSH JOG▲▼**.

AUTO TIMER
→ON
OFF
PRESS (▲,▼) TO SELECT
PRESS (MENU) TO END
- 3** RETURN TO NORMAL SCREEN
Press **MENU** as many times as necessary.

NOTE:

For safety, when **AUTO TIMER** is set to "OFF", all other VCR functions are disabled while the Timer mode is engaged. To disengage the timer, press **TIMER**.

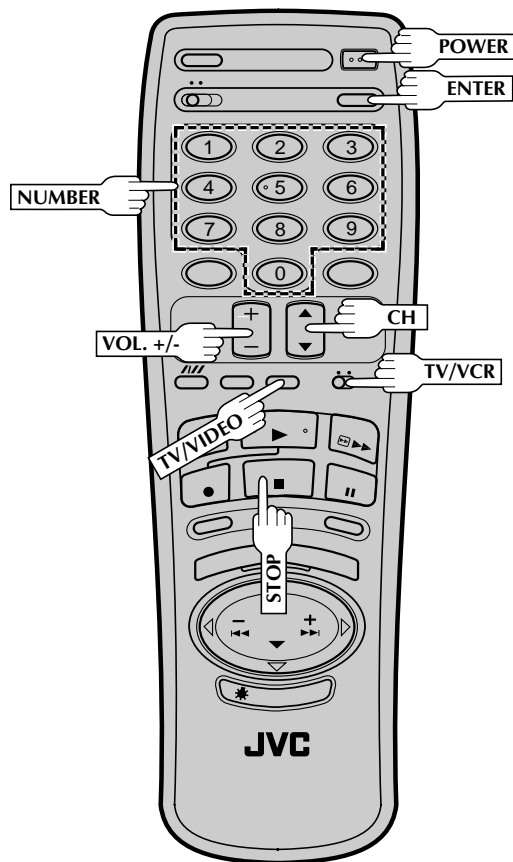

TV Multi-Brand Remote Control

The VCR's remote control can control several functions on JVC remote control TVs and on the brands of remote control TVs listed below. Some TV brands have more than one code. If the TV will not function with one code, try entering another.

1

TURN ON THE TV

Turn the power on using the TV's remote control.

2

SET REMOTE CONTROL MODE

Set the **TV/VCR** switch on the VCR's remote control to TV.

3

SET TV BRAND CODE

Refer to the chart below. While holding down **POWER**, enter your TV's brand code using the **NUMBER** keys, then press **STOP**.

- Once you have set the remote control to operate the TV, you don't have to repeat this step until you replace your remote control's batteries.

4

OPERATE TV

First, press **POWER** on the remote to see if the TV's power goes off as it should. If it does, try other operations.

- The **POWER**, **TV/VIDEO**, **CH**▲▼, **VOL +/-** and **NUMBER** keys on the remote can all be used to operate the TV. *For some brands of TV, you must press **ENTER** after having pressed the **NUMBER** keys.
- To return the remote to VCR control, set the **TV/VCR** switch to **VCR**.

NOTE:

Depending on the kind of TV, there may be cases where some or all functions cannot be operated using the remote control.

TV BRAND NAME	BRAND CODE
JVC	01
PHILIPS	03
PHILICO	05
HITACHI	05
SHARP	06
TOSHIBA	07
MITSUBISHI	08
PHILICO/DAEWOO	09
PACKARD BELL	09
KIOTE/DAEWOO	09
DAEWOO	10
SAMSUNG	11
GOLDSTAR	12
RCA	14
PANASONIC	15, 16
SONY	18
ZONDA	19, 20, 21
AKAWA	21, 22
ELECTRA	23

Edit From A Camcorder

You can use a camcorder as the player and your VCR as the recorder.

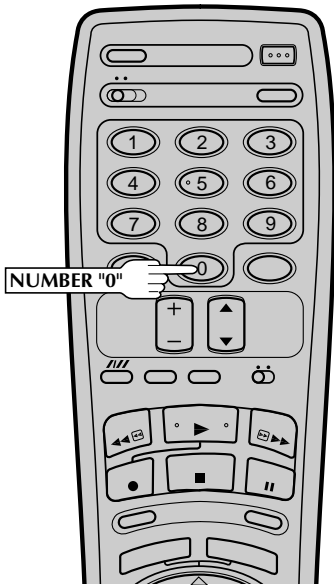
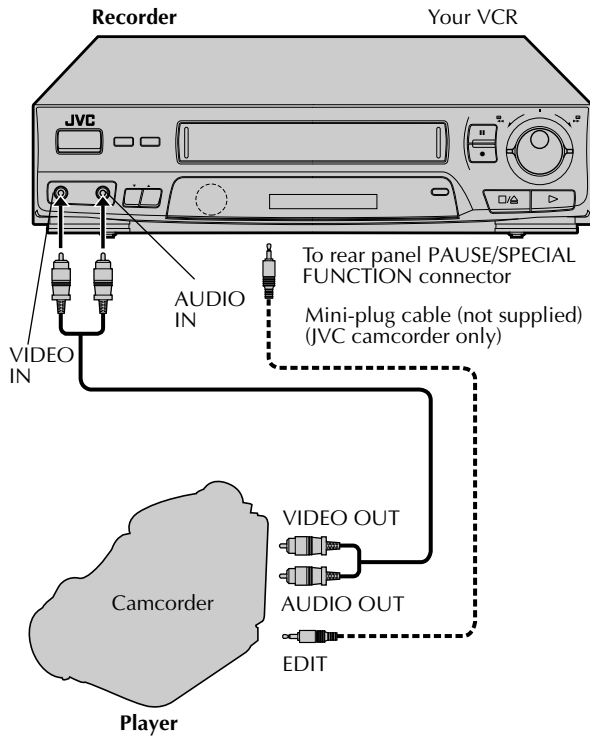

1 MAKE CONNECTIONS

Connect an AV cable between the camcorder's VIDEO OUT and AUDIO OUT connectors and your VCR's VIDEO IN and AUDIO IN connectors.

- When a Master Edit Control-equipped JVC camcorder is used, the camcorder is capable of controlling your VCR. The Mini-plug cable is a mono 3.5 mm mini-plug to mono 3.5 mm mini-plug connector.
- When using a Hi-Fi camcorder, connect its AUDIO OUT L connector to the AUDIO IN connector on your VCR.

2 LOAD A CASSETTE

Insert the cassette to be recorded on into the recorder.

3 SET RECORDER'S INPUT MODE

Press **NUMBER** key "0" to set to AUX.

4 START PLAYER

Set the camcorder to its play mode.

5 START RECORDER

Set your VCR to its record mode.

- If you are using a Master Edit Control-equipped JVC camcorder, it can put the recorder automatically into Record mode. (Refer to camcorder's instruction manual.)

Edit To Or From Another VCR

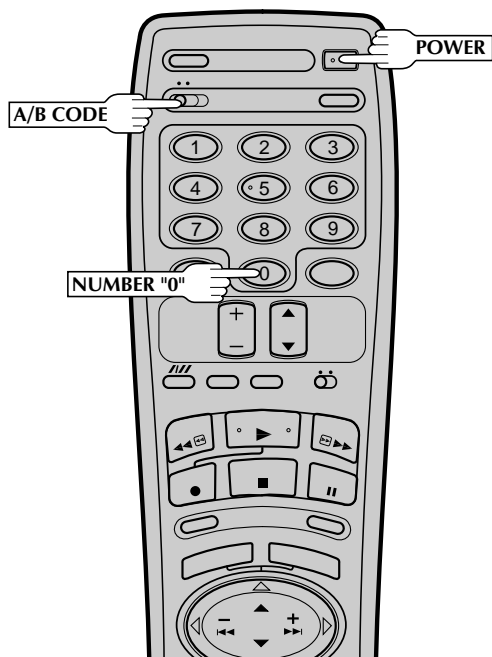
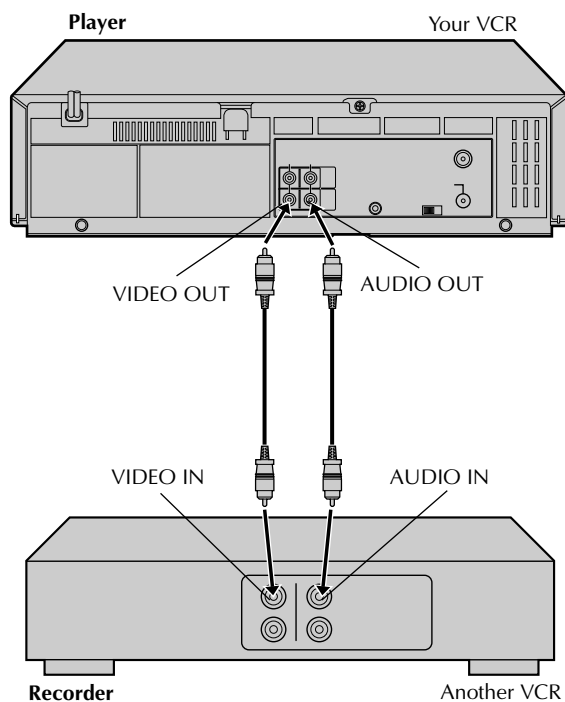

You can use your VCR as the player or the recorder.

1 MAKE CONNECTIONS

Connect an AV cable between the player's VIDEO OUT and AUDIO OUT connectors and the recorder's VIDEO IN and AUDIO IN connectors.

- When connecting to a Hi-Fi VCR, connect your VCR's AUDIO IN/OUT connector to the AUDIO L IN/OUT connector on the Hi-Fi VCR.

2 LOAD CASSETTES

Insert the playback cassette into the player and the cassette to be recorded on into the recorder.

3 SET RECORDER'S INPUT MODE

Set to AUX. With this VCR, press **NUMBER** key "0" (AU appears on the front display panel in place of a channel number).

4 START PLAYER

Set to its play mode.

5 START RECORDER

Set to its record mode.

NOTE:

Connections made to the front panel AUDIO/VIDEO input connectors automatically override those made to the rear panel AUDIO/VIDEO input connectors.

Control Two JVC VCRs

The supplied remote control is capable of controlling two JVC VCRs independently using the **A/B CODE** switch. You can set this VCR so it responds to remote commands only when the switch is set to **B**, and another VCR so it responds to commands when the switch is set to **A**. The switch is preset to **A** because this VCR normally responds to A-code signals. You can easily modify this VCR to accept B-code commands.

- 1 Unplug the VCR's power cord from the AC outlet.
- 2 Set the **A/B CODE** switch on the remote control to **B**.
- 3 Plug the VCR's power cord back into the AC outlet.
- 4 Turn the VCR's power back on by pressing **POWER** on the remote.

The VCR will now respond only to B-code commands.

Random Assemble Editing

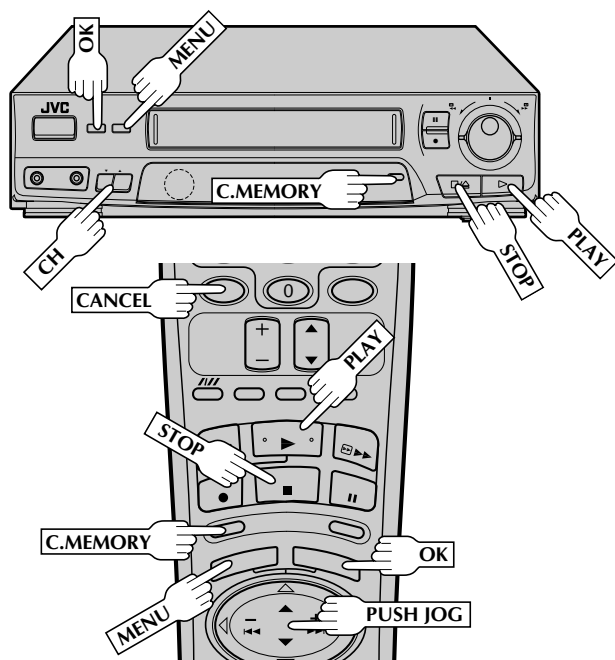
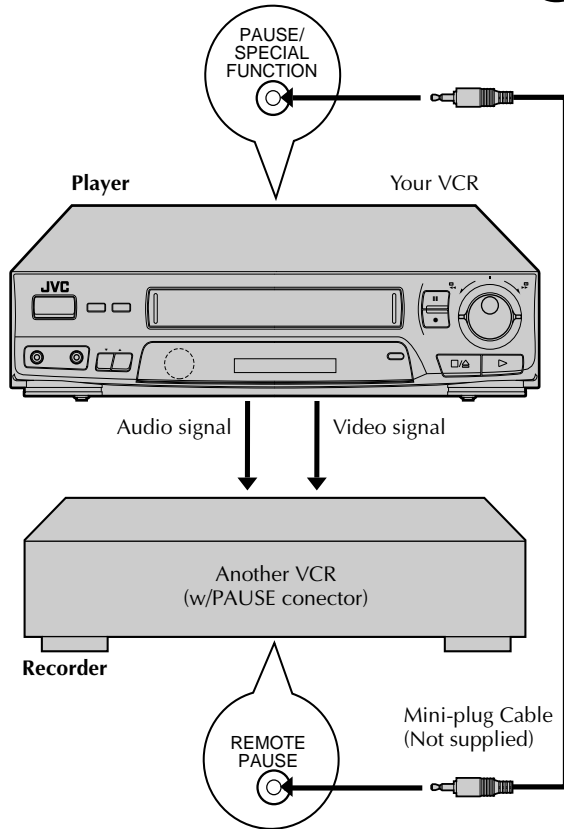

This function makes it easier to create edited videos when your VCR is used as the source player in combination with another VCR equipped with a Remote PAUSE Connector. You can pre-program up to 8 scenes or "cuts" for automatic editing in the sequence you have specified.

1

MAKE CONNECTIONS

Connect your VCR's VIDEO OUT and AUDIO OUT connectors to the VIDEO IN and AUDIO IN connectors on the recording deck, and connect your VCR's PAUSE/SPECIAL FUNCTION connector to the PAUSE connector on the recording deck.

- If the recording deck doesn't have a PAUSE connector, connect to the R.A. EDIT connector instead.
- The Mini-plug cable is a mono 3.5 mm mini-plug to mono 3.5 mm mini-plug connector.

2

PREPARE FOR EDITING

Insert the cassette to be recorded on into the recorder and set the recorder's input mode.

3

LOAD SOURCE CASSETTE

Insert the source cassette into your VCR.

4

START SOURCE PLAYBACK

Press **PLAY**.

5

ACCESS MAIN MENU SCREEN

Press **MENU** to bring up the Main Menu screen.

6

ACCESS R.A. EDIT SCREEN

Place the arrow next to "R.A. EDIT" by pressing **CH▲▼** or **PUSH JOG▲▼**, then press **OK**.





- The screen is superimposed on the video playback in step 7.

MAIN MENU	
PROGRAM SET	
FUNCTION SET	
TUNER SET	
INITIAL SET	
B. E. S. T. PICTURE SYSTEM	
→ R.A. EDIT	
PRESS (▲, ▼), THEN (OK)	
PRESS (MENU) TO END	

Before requesting service for a problem, use this chart and see if you can repair the trouble yourself. Small problems are often easily corrected, and this can save you the trouble of sending your VCR off for repair.

POWER		
SYMPTOM	POSSIBLE CAUSE	CORRECTIVE ACTION
1. The power won't come on.	<ul style="list-style-type: none"> • The power cord is disconnected. 	Connect the power cord.
2. The clock works, but the VCR's power won't come on.	<ul style="list-style-type: none"> • The TIMER mode is engaged with Auto Timer set to "OFF" (☞ pg. 32). 	Press TIMER to disengage.
3. The remote control won't function.	<ul style="list-style-type: none"> • The batteries are discharged. • The A/B CODE switch is in the wrong position. • The TV/VCR switch is in the wrong position. 	Replace the dead batteries with new ones. Re-perform the A/B Code setting (☞ pg. 35). Set the switch to the position corresponding with the unit you want to operate.
TAPE TRANSPORT		
SYMPTOM	POSSIBLE CAUSE	CORRECTIVE ACTION
1. The cassette gets stuck partway during loading, and is ejected.	<ul style="list-style-type: none"> • The cassette was inserted incorrectly. 	Make sure the window side is up, the rear label side is facing you and the arrow on the front of the cassette is pointing towards the VCR. Then insert the cassette
2. The tape stops during rewind or fast forward.	<ul style="list-style-type: none"> • The Counter Memory indicator ("M") is lit on the front display panel. 	Press C.MEMORY to disengage the Counter Memory mode and extinguish the indicator.
PLAYBACK		
SYMPTOM	POSSIBLE CAUSE	CORRECTIVE ACTION
1. The tape is running but the picture won't appear.	<ul style="list-style-type: none"> • If you're using the RF OUT connection (☞ pg. 4), the channel selector on the TV is set incorrectly. • If you're using the AV connection (☞ pg. 4), the TV receiver is set to the wrong mode. 	Set the channel selector to channel 3 or 4. Set the TV receiver to its AV mode.
2. Noise appears during visual search.	<ul style="list-style-type: none"> • This is normal. 	
3. The playback picture is blurred or interrupted, even though TV broadcasts are clear.	<ul style="list-style-type: none"> • The video heads may be dirty. 	The heads must be cleaned. Consult your JVC dealer.
RECORDING		
SYMPTOM	POSSIBLE CAUSE	CORRECTIVE ACTION
1. Recording won't start.	<ul style="list-style-type: none"> • There's no cassette loaded. • The loaded cassette has had its record safety tab removed. 	Insert a cassette. Remove the cassette and cover the hole with adhesive tape, or load a cassette on which the record safety tab is intact.
2. TV broadcasts won't record properly.	<ul style="list-style-type: none"> • The VCR has been set to its AUX mode by mistake. 	Set the VCR to the appropriate channel.
3. Tape-to-tape editing won't work.	<ul style="list-style-type: none"> • The VCRs or the camcorder and the VCR have been incorrectly connected. • The power to one or more of the units has not been turned on. 	Refer to the directions and the illustration under "Edit To Or From Another VCR" (☞ pg. 35) or "Edit From A Camcorder" (☞ pg. 34) and properly connect the units. Make sure the power to all units is on.

TIMER RECORDING

SYMPTOM	POSSIBLE CAUSE	CORRECTIVE ACTION
1. Timer recording won't work.	<ul style="list-style-type: none"> The clock and/or the timer have been set incorrectly. The timer is not engaged. The VCR has not been set up properly. 	Check or re-perform the clock/timer settings to ensure correctness. Press TIMER and check to make sure that TIMER appears on the front display panel. Re-perform the set-up procedures.
2. On-screen timer programming won't work.	<ul style="list-style-type: none"> Timer recording is in progress. 	Timer programming can't be performed when timer recording is in progress. Wait until it finishes.
3. TIMER and  on the front display panel won't stop blinking.	<ul style="list-style-type: none"> The timer is engaged but there's no cassette loaded. 	Load a cassette with the record safety tab intact, or with the hole covered with adhesive tape.
4. The cassette is automatically ejected, and TIMER and  on the front display panel won't stop blinking.	<ul style="list-style-type: none"> The loaded cassette has had its record safety tab removed. 	Remove the cassette and cover its hole with adhesive tape, or replace it with a cassette on which the safety tab is intact.
5. TIMER blinks for 10 seconds and the timer mode is disengaged.	<ul style="list-style-type: none"> TIMER has been pressed when there are no programs in memory, or the timer record program information has not been programmed correctly. 	Check the programmed data and re-program as necessary, then press TIMER again.
6. The cassette is automatically ejected, the power shuts off and TIMER and  won't stop blinking.	<ul style="list-style-type: none"> The end of tape was reached during timer recording. 	The program may not have been recorded in its entirety. Next time make sure you have enough time on the tape to record the entire program.
7. We moved, and now G-Code doesn't work properly.	<ul style="list-style-type: none"> The receivable stations in the new area are received on different channels than those in the previous area. 	Re-perform the G-Code setup procedure ( pg. 9).
8. "PROGRAM FULL" is displayed on the G-Code screen.	<ul style="list-style-type: none"> All 8 programs of the VCR's timer memory are used. 	Wait until a space in memory clears, or cancel unnecessary program information ( pg. 30).

OTHER PROBLEMS

SYMPTOM	POSSIBLE CAUSE	CORRECTIVE ACTION
1. When scanning channels, some of them are skipped over.	<ul style="list-style-type: none"> Those channels have been preset to be skipped. 	If you need the skipped channels, restore them ( pg. 8).
2. The channel can't be changed.	<ul style="list-style-type: none"> Recording is in progress. 	Press PAUSE to pause the recording, change channels, then press PLAY to resume recording.
3. The remote control won't operate my TV.	<ul style="list-style-type: none"> The TV/VCR switch is set to a position other than TV. 	Set the switch to TV.

ATTENTION:

This recorder contains microcomputers. External electronic noise or interference could cause malfunctioning. In such cases, switch the power off and unplug the power cord. Then plug it in again and switch power on. Take out the cassette. After checking the cassette, operate the unit as usual.



PLAYBACK

Q. What happens if the end of the tape is reached during playback or search?

A. The tape is automatically rewound to the beginning.

Q. Can the VCR indefinitely remain in the still mode?

A. No. It stops automatically after 5 minutes to protect the heads.

Q. During search, slow, still and frame-by-frame playback, I can't hear any audio. What's the problem?

A. This is normal.

Q. During search, still and frame-by-frame playback, the picture is intermittent. What's the cause?

A. Picture loss occurs when these types of playback are attempted with a tape recorded in LP mode. Pressing **PLAY** to return to normal playback will restore the picture.

Q. When returning from multi-speed search to normal playback, the picture is disturbed. Should I be concerned about this?

A. No, it is normal.

Q. Noise bars appear during multi-speed search. What's the problem?

A. This is normal.

Q. Other than preventing further recording, what effect does removing the safety tab have?

A. It disables marking of index codes.

Q. Sometimes, during Index Search, the VCR can't find the program I want to see. Why not?

A. There may be index codes too close together.

Q. During playback, on-screen operational indicators sometimes jitter. Why does this happen?

A. If the condition of the tape being played back is not good, jittering of the video (including on-screen indicators) may occur.

RECORDING

Q. When I pause and then resume a recording, the end of the recording before the pause is overlapped by the new recording. Why does this happen?

A. This is normal. It reduces distortion at the pause and resume points.

Q. Can the VCR indefinitely remain in the Record-Pause mode?

A. No. The VCR automatically goes to its Stop mode after 5 minutes to protect the heads. When paused during Instant Timer Recording (ITR), the VCR shuts off automatically after 5 minutes.

Q. What happens if the tape runs out during recording?

A. The VCR automatically rewinds it to the beginning.

TIMER RECORDING

Q. REC and TIMER remain lit on the front display panel. Is there a problem?

A. No. This is a normal condition for a timer recording in progress.

Q. Can I program the timer while I'm watching a tape or a TV broadcast?

A. You won't see the picture as it is replaced by the on-screen menu, but the audio from the program or tape you're viewing is present.





SPECIFICATIONS

41

GENERAL

Power requirement	: AC 110–220 V \sim , 60 Hz
Power consumption	: 16 W
Temperature	
Operating	: 5°C to 40°C
Storage	: –20°C to 60°C
Operating position	: Horizontal only
Dimensions (W x H x D)	: 400 x 94 x 291 mm
Weight	: 3.7 kg
Format	: VHS NTSC standard
Maximum recording time	
SP	: 210 min. with ST-210 video cassette
EP	: 630 min. with ST-210 video cassette

VIDEO/AUDIO

Signal system	: NTSC-type color signal and EIA monochrome signal, 525 lines/60 fields
Recording/ Playback system	: DA-4 (Double Azimuth) head helical scan system
Signal-to-noise ratio	: 45 dB
Horizontal resolution	: 240 lines
Frequency range	: 70 Hz to 10,000 Hz
Input/Output	: RCA connectors (IN x 2, OUT x 1)

TUNER

Tuning system	: Frequency-synthesized tuner
Channel coverage	
VHF	: Channels 2–13
UHF	: Channels 14–69
CATV	: 113 Channels
RF output	: Channel 3 or 4 (switchable; preset to channel 3 when shipped) 75 ohms, unbalanced

TIMER

Clock reference	: Quartz
Program capacity	: 1-year programmable timer/ 8 programs
Memory backup time	: Approx. 18 hours

ACCESSORIES

Provided accessories	: RF cable, Infrared remote control unit, “AA” battery x 2
----------------------	--

Specifications shown are for SP mode unless otherwise specified. E. & O.E. Design and specifications subject to change without notice.





FRONT VIEW

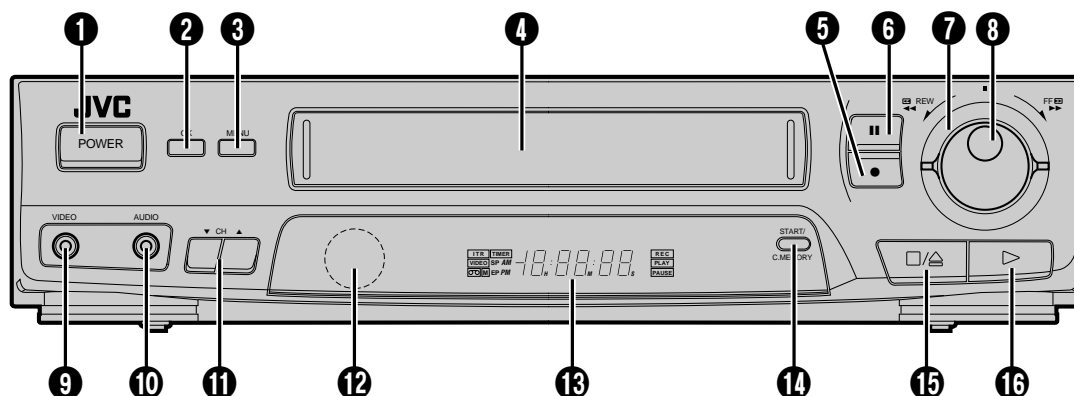

- ❶ Power ON/OFF Button (☞ pg. 5)
- ❷ OK Button (☞ pg. 5)
- ❸ Menu Button (☞ pg. 5)
- ❹ Cassette Loading Slot
- ❺ Record [REC] Button (☞ pg. 13)
- ❻ Pause Button (☞ pg. 13)
- ❼ SHUTTLE Ring (☞ pg. 14)
- ❽ JOG Dial (☞ pg. 14)
- ❾ Video Input Connector (☞ pg. 34)

- ❿ Audio Input Connector [R] (☞ pg. 34)
- ⓫ Channel ▲▼ Buttons (☞ pg. 5)
- ⓬ Remote Control Sensor
- ⓭ Front Display Panel (☞ pg. 43)
- ⓮ START Button (☞ pg. 36)
- ⓯ Counter [C.] MEMORY (☞ pg. 19)
- ⓰ Stop/Eject Button (☞ pg. 12)
- ⓱ Play Button (☞ pg. 12)

REAR VIEW

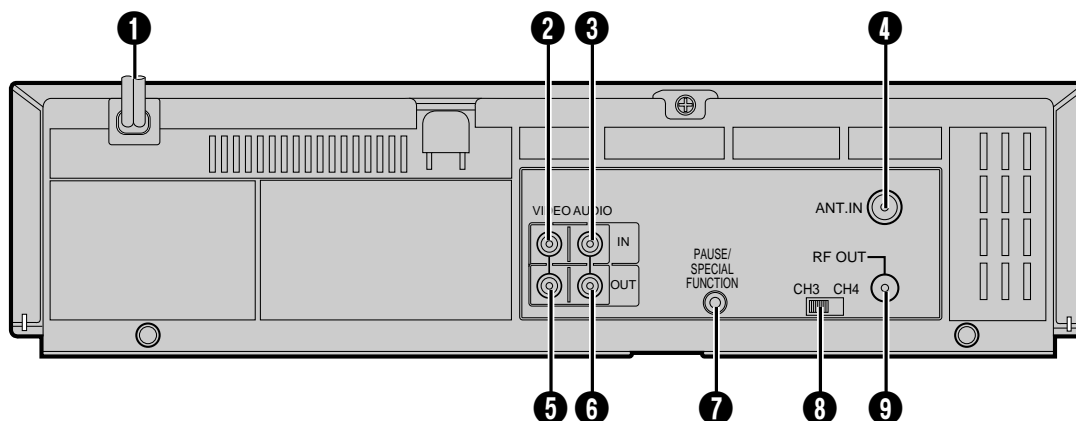

- ❶ Power Cord (☞ pg. 4)
- ❷ Video Input Connector (☞ pg. 35)
- ❸ Audio Input Connector (☞ pg. 35)
- ❹ ANT. IN Connector (☞ pg. 4)
- ❺ Video Output Connector (☞ pg. 4)
- ❻ Audio Output Connector (☞ pg. 4)

- ❼ PAUSE/SPECIAL FUNCTION Connector
 - Remote PAUSE Connector (☞ pg. 34)
 - Random Assemble Editing connector (☞ pg. 36)
- ❽ Channel 3/4 Switch (☞ pg. 4)
- ❾ RF OUT Connector (☞ pg. 4)

FRONT DISPLAY PANEL

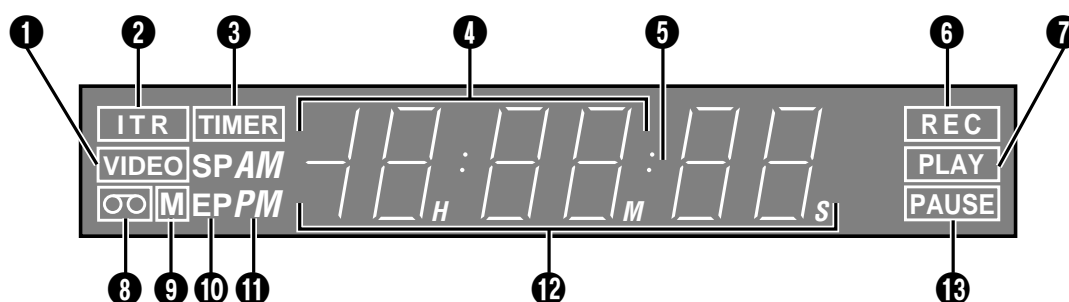

- 1 Video Mode Indicator (☞ pg. 5)
- 2 Instant Timer Recording Indicator (☞ pg. 25)
- 3 Timer Mode Indicator (☞ pg. 27)
- 4 Clock Display (☞ pg. 5)
- 5 Counter Display (☞ pg. 19)
- 6 Recording Mode Indicator (☞ pg. 13)
- 7 Play Mode Indicator (☞ pg. 12)
- 8 "Cassette Loaded" Mark
- 9 Counter Memory Mark (☞ pg. 19)
- 10 Tape Speed Indicators (☞ pg. 13)
- 11 AM/PM Indicators (☞ pg. 5)
- 12 Channel Display ["AU" for AUX mode] (☞ pg. 34)
- 13 Pause Mode Indicator (☞ pg. 13)

REMOTE CONTROL (Provided)

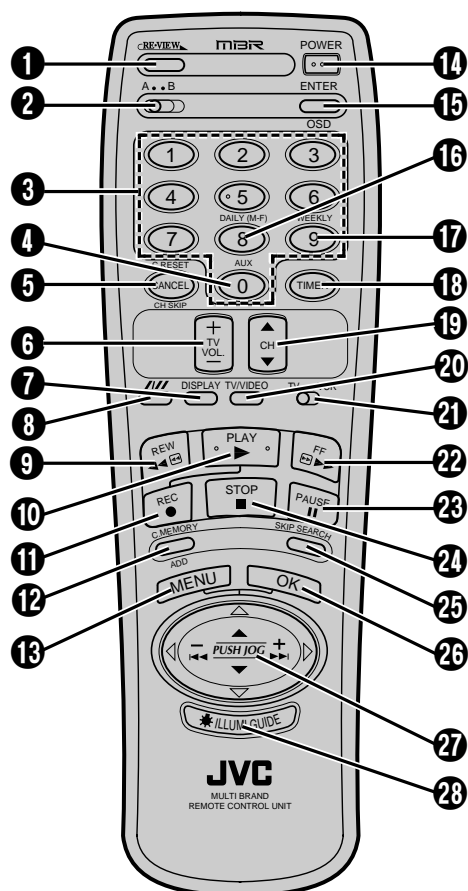

- 1 Instant REVIEW Button (☞ pg. 19)
- 2 A/B Code Select Switch (☞ pg. 35)
- 3 NUMBER Buttons (☞ pg. 5)
- 4 "AUX" Mode Select Button (☞ pg. 34)
- 5 CANCEL Button (☞ pg. 30)
- 6 Volume [VOL] +/- Buttons (☞ pg. 33)
- 7 DISPLAY Button (☞ pg. 19)
- 8 Recording Speed [SP/EP] Button (☞ pg. 13)
- 9 Rewind [REW] Button (☞ pg. 12)
- 10 PLAY Button (☞ pg. 12)
- 11 Record [REC] Button (☞ pg. 13)
- 12 Counter [C.] MEMORY Button (☞ pg. 19)
- 13 MENU Button (☞ pg. 5)
- 14 POWER ON/OFF Button (☞ pg. 5)
- 15 ENTER Button (☞ pg. 13)
- 16 DAILY Timer Recording Button (☞ pg. 27)
- 17 WEEKLY Timer Recording Button (☞ pg. 27)
- 18 TIMER Button (☞ pg. 27)
- 19 Channel [CH] ▲▼ Buttons (☞ pg. 5)
- 20 TV/VIDEO Button (☞ pg. 5)
- 21 TV/VCR Switch (☞ pg. 33)
- 22 Fast-Forward [FF] Button (☞ pg. 12)
- 23 PAUSE Button (☞ pg. 12)
- 24 STOP Button (☞ pg. 12)
- 25 SKIP SEARCH Button (☞ pg. 18)
- 26 OK Button (☞ pg. 5)
- 27 PUSH JOG Button (☞ pg. 5)
- 28 ILLUMI GUIDE Button (☞ pg. 26)

** If the remote control doesn't work properly, remove its batteries, wait a short time and then try again.

HR-J430KR

JVC
VICTOR COMPANY OF JAPAN, LIMITED

COPYRIGHT © 1996 VICTOR COMPANY OF JAPAN, LTD.

KR  Printed in Malaysia
0796MNV*UN*PJ